



SERVICE MANUAL

VHF TRANSCEIVER
IC-T3H

INTRODUCTION

This service manual describes the latest service information for the **IC-T3H** at the time of publication.

To upgrade quality, all electrical or mechanical parts and internal circuits are subject to change without notice or obligation.

DANGER

NEVER connect the transceiver to an AC outlet or to a DC power supply that uses more than 10.3 V. Such a connection could cause a fire hazard and/or electric shock.

DO NOT expose the transceiver to rain, snow or any liquids.

DO NOT reverse the polarities of the power supply when connecting the transceiver.

DO NOT apply an RF signal of more than 20 dBm (100mW) to the antenna connector. This could damage the transceiver's front end.

ORDERING PARTS

Be sure to include the following four points when ordering replacement parts:

1. 10-digit order numbers
2. Component part number and name
3. Equipment model name and unit name
4. Quantity required

<SAMPLE ORDER>

0910053802	PCB B-5649B	IC-T3H	MAIN UNIT	1 pieces
8810009560	Screw BT M2 x 6 ZK	IC-T3H	Chassis	10 pieces
8810009510	Screw BT 2 x 4 NI	IC-T3H	Chassis	10 pieces

Addresses are provided on the inside back cover for your convenience.



REPAIR NOTES

1. Make sure a problem is internal before disassembling the transceiver.
2. **DO NOT** open the transceiver until the transceiver is disconnected from its power source.
3. **DO NOT** force any of the variable components. Turn them slowly and smoothly.
4. **DO NOT** short any circuits or electronic parts. An insulated turning tool **MUST** be used for all adjustments.
5. **DO NOT** keep power ON for a long time when the transceiver is defective.
6. **DO NOT** transmit power into a signal generator or a sweep generator.
7. **ALWAYS** connect a 40 dB to 50 dB attenuator between the transceiver and a deviation meter or spectrum analyzer when using such test equipment.
8. **READ** the instructions of test equipment thoroughly before connecting equipment to the transceiver.

TABLE OF CONTENTS

SECTION 1	SPECIFICATIONS	
SECTION 2	INSIDE VIEWS	
SECTION 3	DISASSEMBLY INSTRUCTIONS	
SECTION 4	CIRCUIT DESCRIPTION	
4 - 1	RECEIVER CIRCUITS	4 - 1
4 - 2	TRANSMITTER CIRCUITS	4 - 2
4 - 3	PLL CIRCUIT	4 - 3
4 - 4	OTHER CIRCUITS	4 - 3
4 - 5	POWER SUPPLY CIRCUITS	4 - 3
4 - 6	CPU PORT ALLOCATIONS	4 - 4
SECTION 5	ADJUSTMENT PROCEDURES	
5 - 1	PREPARATION.....	5 - 1
5 - 2	PLL ADJUSTMENT.....	5 - 2
SECTION 6	PARTS LIST	
SECTION 7	MECHANICAL PARTS AND DISASSEMBLY	
SECTION 8	SEMI-CONDUCTOR INFORMATION	
SECTION 9	BOARD LAYOUTS	
9 - 1	MAIN UNIT.....	9 - 1
SECTION 10	BC-146 OPTIONAL DESKTOP CHARGER INFORMATION	
10 - 1	PARTS LIST.....	10 - 1
10 - 2	DISASSEMBLY INFORMATION.....	10 - 1
10 - 3	VOLTAGE DIAGRAM.....	10 - 2
10 - 4	BOARD LAYOUT	10 - 2
SECTION 11	BLOCK DIAGRAM	
SECTION 12	VOLTAGE DIAGRAM	

SECTION 1 SPECIFICATIONS

■ GENERAL

- Frequency coverage : TX/RX 144.000–146.000 MHz
- Type of emission : F2D/ F3E
- Frequency stability : ± 10 ppm
(-10°C to $+60^{\circ}\text{C}$; $+14^{\circ}\text{F}$ to $+140^{\circ}\text{F}$)
- Tuning steps : 5, 10, 12.5, 15, 20, 25, 30 or 50 kHz
- Antenna connector : BNC (50 Ω)
- Power supply requirement : 7.2 V DC (Operable voltage range: 6.0 to 10.3 V)
(negative ground)
- Number of memory channel : 100 channels
- Call channel : 1 channel
- Scanning mode : Program, Memory, Skip, Priority or Tone
- Current drain (approx.) : Transmit at High (5.5 W) 2.0 A
at Low (0.5 W) 0.7 A
Receive Max. audio 250 mA
stand-by 70 mA
power saved 20 mA
- Usable temperature range : -10°C to $+60^{\circ}\text{C}$; $+14^{\circ}\text{F}$ to $+140^{\circ}\text{F}$
- Dimensions (projections not included) : 54(W) \times 132(H) \times 35(D) mm; 2 1/8(W) \times 5 3/16(H) \times 1 3/8(D) in.
- Weight (with ant., BP-222) : 350 g; 12.3 oz.

■ TRANSMITTER

- RF output power (at 7.2 V DC
(with supplied battery pack) : 5.5 W / 0.5 W (High / Low)
- Modulation system : Variable reactance frequency modulation
- Maximum frequency deviation : ± 5.0 kHz
- Spurious emissions : Less than -60 dB
- Ext. microphone connector : 3-conductor 2.5(d) mm (1/10")/2.2 k Ω

■ RECEIVER

- Receive system : Double conversion superheterodyne system
- Intermediate frequencies : 1st 21.7 MHz
2nd 450 kHz
- Sensitivity : 0.16 μV at 12 dB SINAD (typical)
- Squelch sensitivity : 0.1 μV at threshold (typical)
- Adjacent channel selectivity : 65 dB (typical)
- Spurious response rejection : 75 dB (typical)
- Intermodulation rejection ratio : 65 dB (typical)
- Audio output power (at 7.2 V DC) : More than 300 mW at 10% distortion with an 8 Ω load
- Ext. speaker connector : 3-conductor 3.5(d) mm (1/8")/8 Ω

All stated specifications are subject to change without notice or obligation.

SECTION 2 INSIDE VIEWS

TOP VIEW

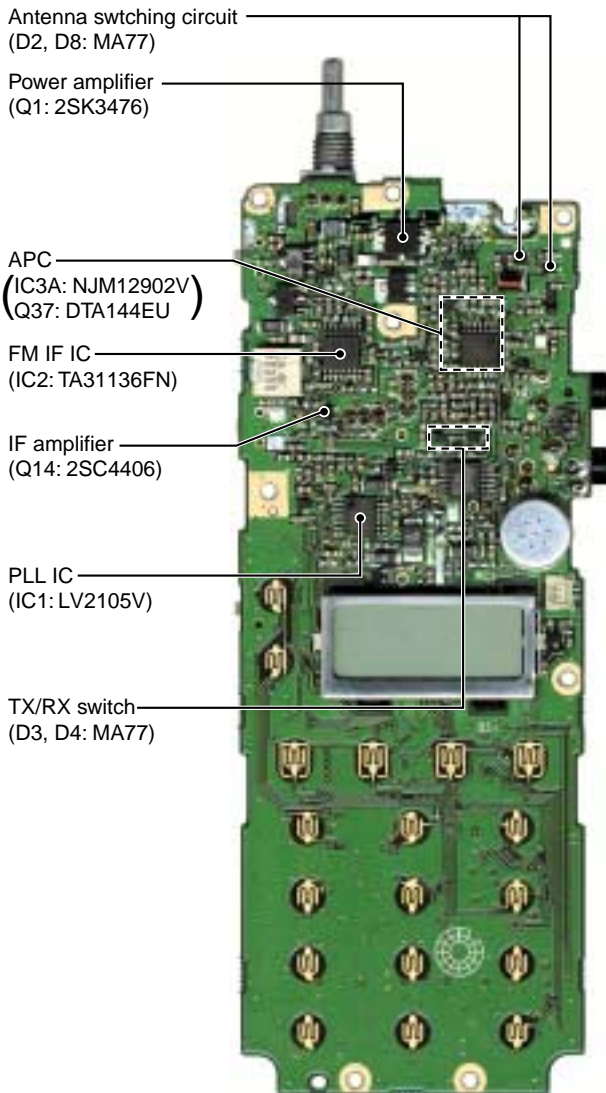

BOTTOM VIEW

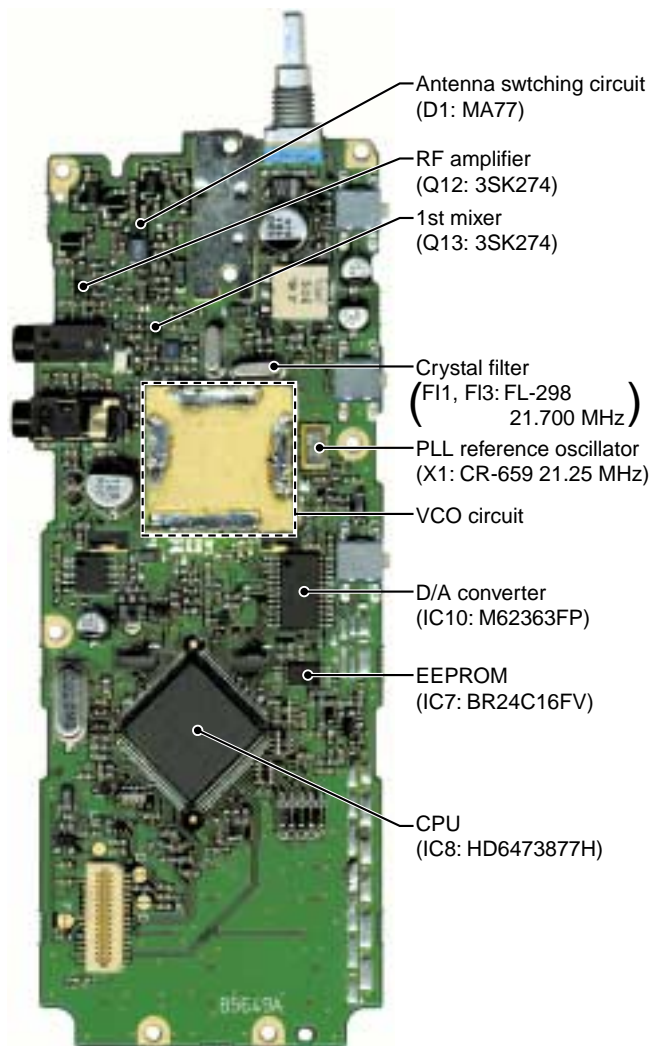

SECTION 3 DISASSEMBLY INSTRUCTIONS

3-1 DISASSEMBLY INSTRUCTION

• REMOVING THE CHASSIS PANEL

- ① Unscrew 1 nut (A), and remove 1 knob (B).
- ② Unscrew 2 screws (C).
- ③ Take off the chassis in the direction of the arrow.
- ④ Unplug J6 to separate front panel and chassis.

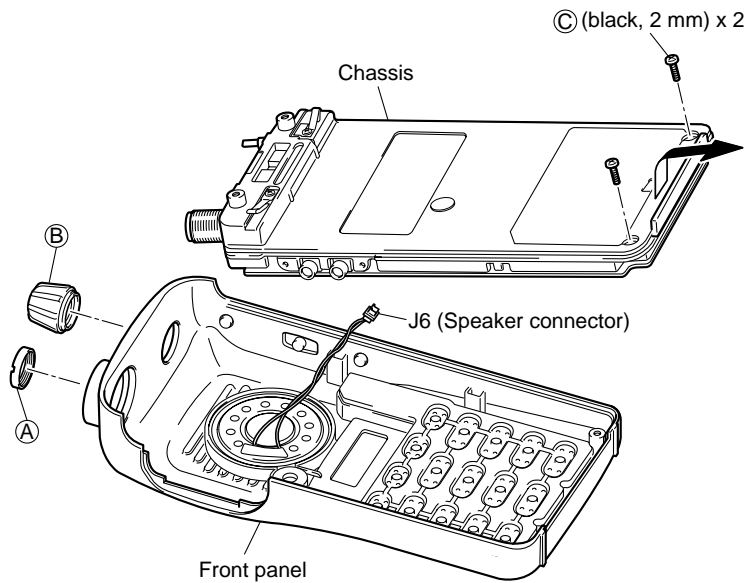

• REMOVING THE MAIN UNIT

- ① Unsolder 3 nut (D), and unscrew 1 nut (E).
- ② Unscrew 2 screws (F), 2 screws (H), and 6 screws (G) (silver, 2 mm) to separate the chassis and the MAIN unit.
- ③ Take off the MAIN unit in the direction of the arrow.

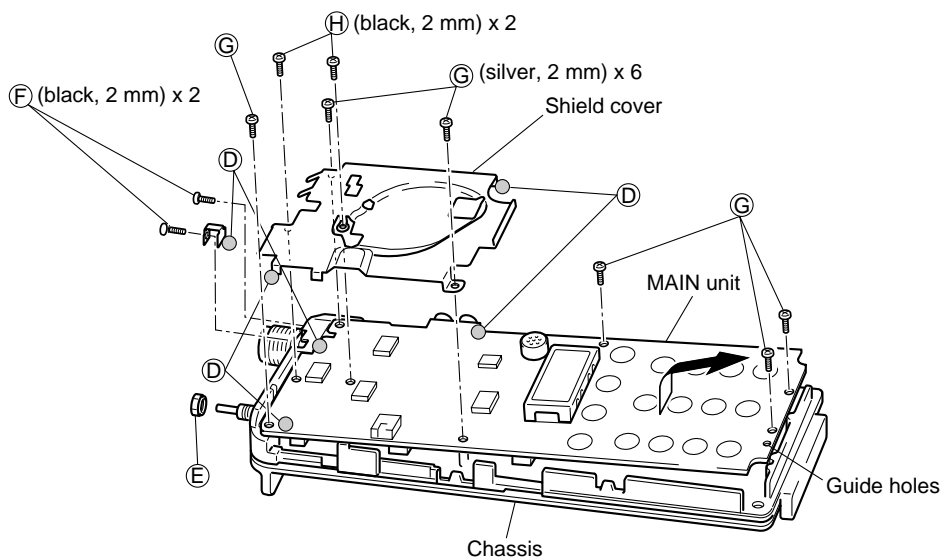

3-2 OPTIONAL UNIT INSTALLATIONS

- ① Remove the option cover.
- ② Remove the bottom protective paper of spoge.
- ③ Connect the UT-108 optional unit to J5.
- ④ Replace the option cover to the chassis-hole.

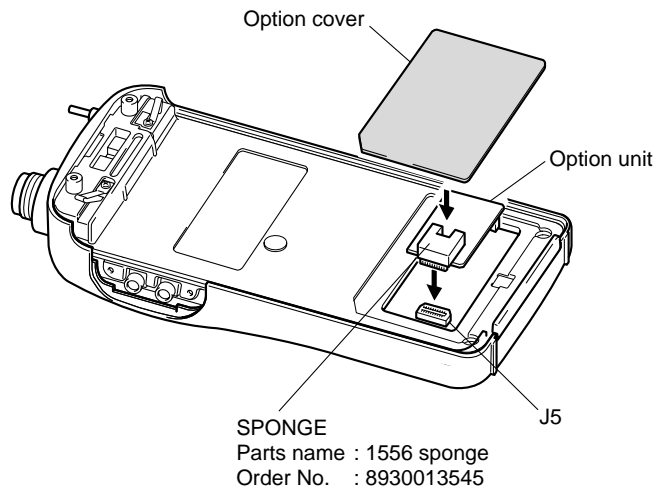

SECTION 4 CIRCUIT DESCRIPTION

4-1 RECEIVER CIRCUITS

4-1-1 ANTENNA SWITCHING CIRCUIT

Received signals passed through the low-pass filter (L1, L2, C1–C5). The filtered signals are applied to the 1/4 λ type antenna switching circuit (D1, D2, D8, L15, C76).

The antenna switching circuit functions as a low-pass filter while transmitting. However, its impedance becomes very high while D2 and D8 are turn ON. Thus transmit signals are blocked from entering the receiver circuits. The antenna switching circuit employs a 1/4 λ type diode switching system. The passed signals are then applied to the RF amplifier circuit.

4-1-2 RF CIRCUIT

The RF circuit amplifies signals within the range of frequency coverage and filters out-of-band signals.

The signals from the antenna switching circuit are applied to the limiter (D50), and are then passed through the band-pass filter (D9, L16, C80). The filtered signals are amplified at the RF amplifier (Q12), then applied to the 1st mixer circuit after out-of-band signals are suppressed at the band-pass filter (D11, D12, L19, C91–C97).

D9, D11, D12 employ varactor diodes that track the band-pass filters and are controlled by the T1–T3 signals from the D/A convertor (IC10, pins 2, 3, 10). These diodes tune the center frequency of an RF passband for wide bandwidth receiving and good image rejection.

4-1-3 1ST MIXER AND 1ST IF CIRCUITS

The 1st mixer circuit converts the received signal to a fixed frequency of the 1st IF signal with a PLL output frequency. By changing the PLL frequency, only the desired frequency will pass through two crystal filters at the next stage of the 1st mixer.

The signals from the RF circuit are mixed at the 1st mixer (Q13) with a 1st LO signal coming from the VCO circuit to produce a 21.70 MHz 1st IF signal.

The 1st IF signal is applied to two crystal filters (F11 and F13) to suppress out-of-band signals. The filtered 1st IF signal is applied to the IF amplifier (Q14), then applied to the 2nd mixer circuit (IC1, pin 16).

4-1-4 2ND IF AND DEMODULATOR CIRCUITS

The 2nd mixer circuit converts the 1st IF signal to a 2nd IF signal. A double conversion superheterodyne system (which converts receive signal twice) improves the image rejection ratio and obtain stable receiver gain.

The 1st IF signal from the IF amplifier is applied to the 2nd mixer section of the FM IF IC (IC2, pin 16), and is mixed with the 2nd LO signal to be converted to a 450 kHz 2nd IF signal.

The FM IF IC contains the 2nd mixer, limiter amplifier, quadrature detector and active filter circuits. A 21.25 MHz 2nd LO signal is produced at the PLL circuit.

The 2nd IF signal from the 2nd mixer (IC2, pin 3) passes through a ceramic filter (F12) to remove unwanted heterodyned frequencies. It is then amplified at the limiter amplifier (IC2, pin 5) and applied to the quadrature detector (IC2, pins 10, 11) to demodulate the 2nd IF signal into AF signals.

4-1-5 AF CIRCUIT

The AF amplifier circuit amplifies the demodulated AF signals to drive a speaker.

AF signals from the FM IF IC (IC2, pin 9) are applied to the analog switch (IC4, pin 1) via the AF filter circuit (IC3b, pins 6, 7). The output signals from pin 2, 3 are passed through the low-pass filter (IC3d, pins 13, 14), and are then applied to the analog switch (IC4, pin 9, 10) again. The signals from the IC4, pin 11 are applied to the AF power amplifier (IC5, pin 4) after passing through the D/A convertor (IC10, pins 12, 11).

• 2ND IF AND DEMODULATOR CIRCUITS

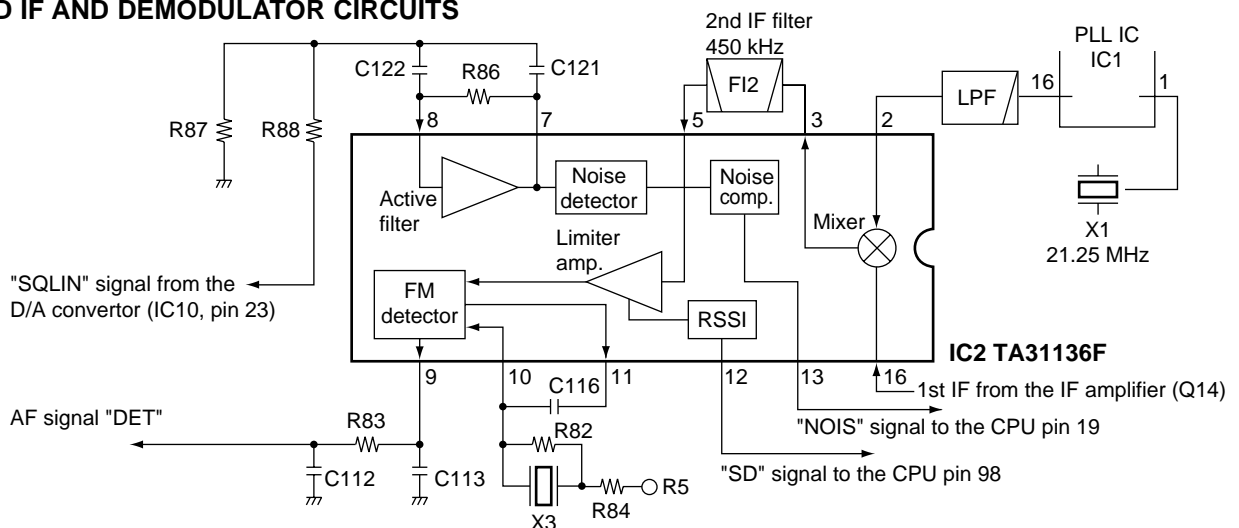

The AF signals are applied to the AF power amplifier circuit (IC5, pin 4) to obtain the specified audio level. The amplified AF signals, output from pin 10, are applied to the internal speaker (SP1) via the speaker jack (CHASSIS unit; J3) when no plug is connected to the jack.

4-1-6 SQUELCH CIRCUIT

A squelch circuit cuts out AF signals when no RF signals are received. By detecting noise components in the AF signals, the squelch switches the analog switch.

A portion of the AF signals from the FM IF IC (IC2, pin 9) are applied to the active filter section (IC2, pin 8) where noise components are amplified and detected with an internal noise detector.

The trigger circuit converts the detected signals to a HIGH or LOW signal and applies this (from pin 13) to the CPU (IC8, pin 19) as the NOIS signal. When the CPU receives a HIGH level NOIS signal, the CPU controls the RMUT line to cut the AF signals at the analog switch IC (IC4). At the same time, the AFON line controls the AF regulator circuit (Q15, Q16) to cut out the VCC power source for the AF power amplifier (IC5).

4-2 TRANSMITTER CIRCUITS

4-2-1 MICROPHONE AMPLIFIER CIRCUIT

The microphone amplifier circuit amplifies audio signals with +6 dB/octave pre-emphasis from the microphone to a level needed for the modulation circuit.

The AF signals from the microphone are applied to the microphone amplifier circuit (IC3c, pin 10). The amplified AF signals are passed through the low-pass filter circuit (IC3d, pins 13, 14) via the analog switch (IC4, pins 4, 3). The filtered AF signals are applied to the modulator circuit after passing through the analog switch (IC4, pins 8, 9).

4-2-2 MODULATION CIRCUIT

The modulation circuit modulates the VCO oscillating signal (RF signal) using the microphone audio signals.

The audio signals (SHIFT) change the reactance of D37 to modulate an oscillated signal at the VCO (Q50, D38). The oscillated signal is amplified at the LO (Q6) and buffer (Q4) amplifiers, then applied to the TX/RX switch circuit (D3, D4).

4-2-3 DRIVE/POWER AMPLIFIER CIRCUITS

The signal from the VCO circuit passes through the TX/RX switching circuit (D3) and is amplified at the pre-drive (Q3), drive (Q2) and power (Q1) amplifiers to obtain 5.5 W of RF power (at 7.2 V DC/typical). The amplified signal passes through the low-pass filter (L4, C278, C287), and then applied to the antenna switching circuit (D1). The signal is applied to the antenna connector (J1) after being passed through the low-pass filter (L1, L2, C1-C5).

The bias current of the drive (Q2) and power (Q1) amplifiers is controlled by the APC circuit to stabilize the output power.

4-2-4 APC CIRCUIT

The APC (Automatic Power Control) circuit (IC3a, Q37) protects drive and power amplifiers from excessive currents and selects HIGH or LOW output power.

The output voltage from the power detector circuit (D32, D33) is applied to the differential amplifier (IC3a, pin 2), and the "T3" signal from the D/A convertor (IC10, pin 10) is applied to the other input for reference.

When the driving current increases, the input voltage of the differential amplifier (IC3a, pin 2) will be increased. In such cases, the differential amplifier output voltage (pin 1) is decreased to reduce the drive current.

Q37 is controlled by the TXC signal from the CPU (IC8, pin 55) to select HIGH or LOW output power.

• APC CIRCUIT

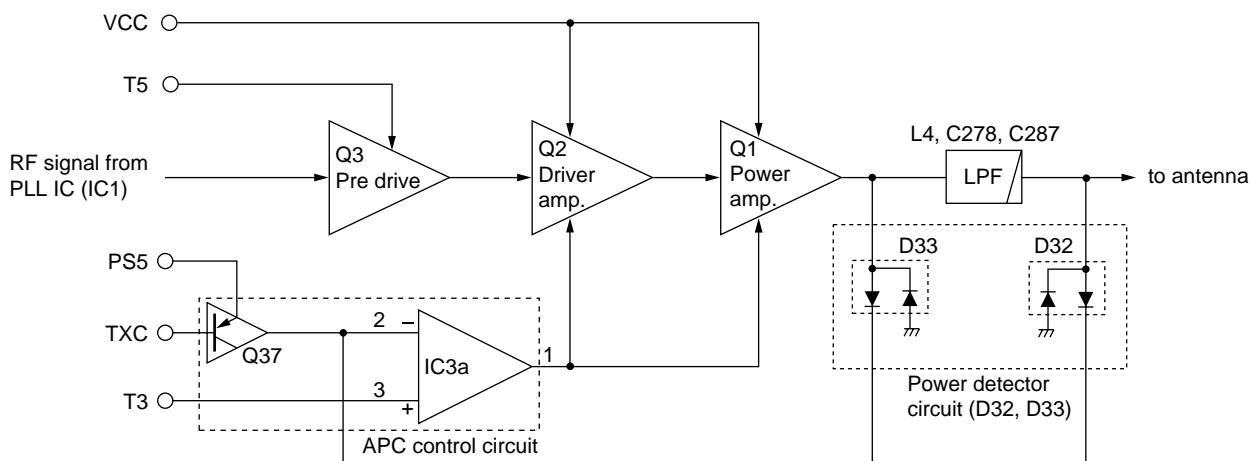

4-3 PLL CIRCUITS

A PLL circuit provides stable oscillation of the transmit frequency and receive 1st LO frequency. The PLL output compares the phase of the divided VCO frequency to the reference frequency. The PLL output frequency is controlled by the divided ratio (N-data) of a programmable divider.

The PLL circuit contains the VCO circuit (Q50, D38). The oscillated signal is amplified at the LO (Q6) and buffer (Q5) amplifiers and then applied to the PLL IC (IC1, pin 6).

The PLL IC contains a prescaler, programmable counter, programmable divider, phase detector, charge pump, etc. The entered signal is divided at the prescaler and programmable counter section by the N-data ratio from the CPU. The divided signal is detected on phase at the phase detector using the reference frequency.

If the oscillated signal drifts, its phase changes from the reference frequency, causing a lock voltage change to compensate for the drift in the oscillated frequency.

A portion of the VCO circuit is amplified at the LO (Q6) and buffer (Q4) amplifiers and is then applied to the receive 1st mixer or transmit pre-drive amplifier circuit via the TX/RX switching diode (D3, D4).

4-4 OTHER CIRCUITS

4-4-1 TONE SQUELCH CIRCUIT

A portion of the detected audio signals from the "DET" line are passed through the tone filter (Q53). The filtered signal is then applied to the CPU (IC1, pin 94) via the "CTCIN" signal, and is compared with the programmed tone signal. The CPU (IC1) outputs control signals as "CTCC" signal to the AF mute and AF regulator circuits to open the squelch when a matched tone signal is received.

The programmed subaudible tone signal is output from the CPU (IC1, pin 91) directly when transmitting with a tone.

4-5 POWER SUPPLY CIRCUITS VOLTAGE LINE

LINE	DESCRIPTION
VCC	The voltage from the attached battery pack.
CPU5	Common 5 V converted from the VCC line by the CPU5 regulator (IC12). The output voltage is applied to the CPU (IC8), EEPROM (IC7) and reset IC (IC11).
SW5V	Common 5 V converted from the VCC line by the SW5 regulator circuit (Q55, Q57, D39). The output voltage is applied to the T5, R5, PS5 and VCO5 regulator circuits, D/A convertor (IC10, pin 16), etc.
VCO5	Common 5 V converted from the SW5V line by the VCO5 regulator circuit (Q11) using the LO (Q6) and buffer (Q4, Q5) amplifiers. The VCO5 regulator circuit is controlled by the PSVCO line from the CPU (IC8, pin 62).
PS5	Common 5 V converted from the SW5V line by the PS5 regulator circuit (Q54) using the analog switch (IC14, pin 14) and APC controller (Q37). The PS5 regulator circuit is controlled by the PS5C line from the CPU (IC8, pin 63).
R5	5 V for receiver circuits converted from the SW5V line by the R5 regulator circuit (Q21) using the 2nd IF IC (IC2, pin 4), RF (Q12) and IF (Q14) amplifiers, etc. The R5 regulator circuit is controlled by the R5C line from the CPU (IC8, pin 53).
T5	5 V for the transmitter circuit converted from the SW5V line by the T5 regulator circuit (Q22) using the pre-drive amplifier (Q3). The T5 regulator circuit is controlled by the T5C line from the CPU (IC8, pin 54).

• PLL CIRCUIT

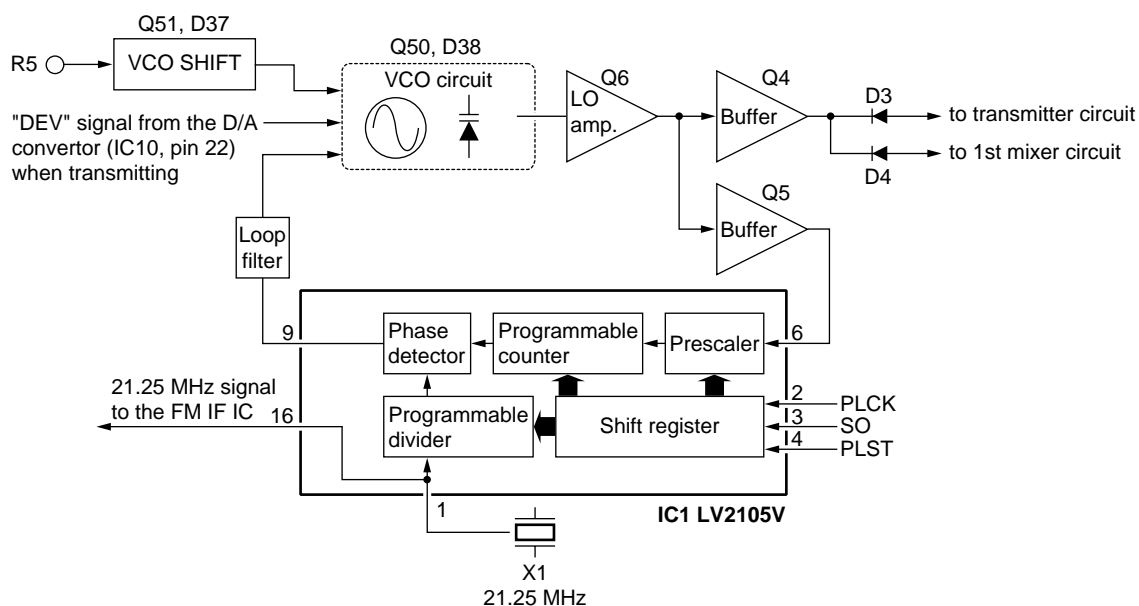

4-6 PORT ALLOCATIONS

4-6-1 CPU (IC8)

Pin number	Port name	Description
1	DICK	Input port for the clock signal from the [DIAL] (S801).
9	RESET	Input port for reset signal.
11	CSIFT	Outputs reference oscillator for the CPU control signal.
12	SCK	Outputs serial clock signal to the PLL IC (IC1, pin 2), D/A convertor IC (IC10, pin 7) and optional unit.
14	SO	Outputs serial signals to the PLL IC (IC1, pin 3), D/A convertor IC (IC10, pin 8) and optional unit.
16	CLIN	Input port for the cloning signal.
17	CLOUT	Outputs the cloning signal.
19	NOIS	Input port for noise signals (pulse type).
21	S1	Input port for the power switch. Low : While POWER switch is pushed.
23-25	OPV1- OPV3	I/O ports for optional unit detection signals from/to J5.
26	CONT	Outputs LCD contrast control signal.
28-30	V3-V1	Input port for the bias signals for the LCD.
32-35	COM4- COM1	Outputs LCD common signals.
44-47	KR3- KR0	Input port for initial matrix. Low : While keys are pushing.
48	UNLK	Input port for PLL unlock signal from the PLL IC (IC1, pin 14). Low : During lock.
49	RMUT	<ul style="list-style-type: none"> • Outputs RX mute control signal. • Input port for the RX mute signal from the optional unit.
50	MMUT	<ul style="list-style-type: none"> • Outputs TX mute control signal. • Input port for the TX mute signal from the optional unit.
51	DUSE	Outputs low-pass filter cut-off frequency control signal when DTCS is activated.
52	PCON	Outputs SW5 regulator (Q55, Q57, Q39) control signal. Low : While power is ON.
53	R5C	Outputs R5 regulator (Q21) control signal. Low : While receiving.
54	T5C	Outputs T5 regulator (Q22) control signal. Low : While transmitting.
55	TXC	Outputs APC circuit (Q37, IC3) control signal. High : While transmitting.

Pin number	Port name	Description
56	AFON	Outputs control signal for the regulator circuit of AF power amplifier. High : When squelch is open, etc.
57	LIGT	Outputs LCD backlight control signal. High : Lights ON.
58	ESCK	Outputs EEPROM (IC7, pin 6) clock signal.
59	ESDA	I/O port for the data signals from/to the EEPROM (IC7, pin 5).
60	DAST	I/O port for strobe signals from/to the D/A convertor IC (IC10, pin 6).
61	PLST	Outputs strobe signals to the PLL IC (IC1, pin 4).
62	PSVCO	Outputs VCO5 regulator (Q11) control signal. Low : While power is ON.
63	PS5C	Outputs PS5 regulator (Q54) control signal. Low : While power is ON.
64-87	SEG1- SEG23	Output LCD driver signals.
90	CTCC	Outputs CTCSS and DTCS tone signal.
91	TONE	Outputs DTMF, BEEP and 1750 Hz tone signal.
94	CTCIN	Input port for CTCSS and DTCS decoded signals.
95	PTT	Input port for the [PTT] switch. High : While [PTT] switch is pushed.
96	DIUD	Input port for the UP/DOWN signal from the [DIAL] (S801).
97	REMO	Input port for the remote signals from an optional microphone (HM-75A) via the [MIC] jack.
98	SD	Input port for the RSSI detection.
99	LVIN	Input port for the PLL lock voltage.
100	TEMP	Input port for the transceiver's internal temperature detection.

4-6-2 D/A CONVERTOR IC (IC10)

Pin number	Port name	Description
2, 3	T1, T2	Output tunable bandpass filter control signals.
10	T3	<ul style="list-style-type: none">• Outputs tunable bandpass filter control signal while receiving.• Outputs TX power control signal while transmitting.
11	VOLOUT	Outputs AF volume control signal.
14	DTC	Outputs DTCS's gradient control signal.
15	FC	Outputs reference frequency control signal to X1.
22	DEV	Outputs transmit deviation control signal.
23	SQLIN	Outputs squelch control signal.

SECTION 5 ADJUSTMENT PROCEDURES

5-1 PREPARATION

■ REQUIRED TEST EQUIPMENT

EQUIPMENT	GRADE AND RANGE	EQUIPMENT	GRADE AND RANGE
DC power supply	Output voltage : 7.2 V DC Current capacity : 5 A or more	Digital multimeter	Input impedance : 10 M Ω /V DC or better

• DC POWER CABLE CONNECTION

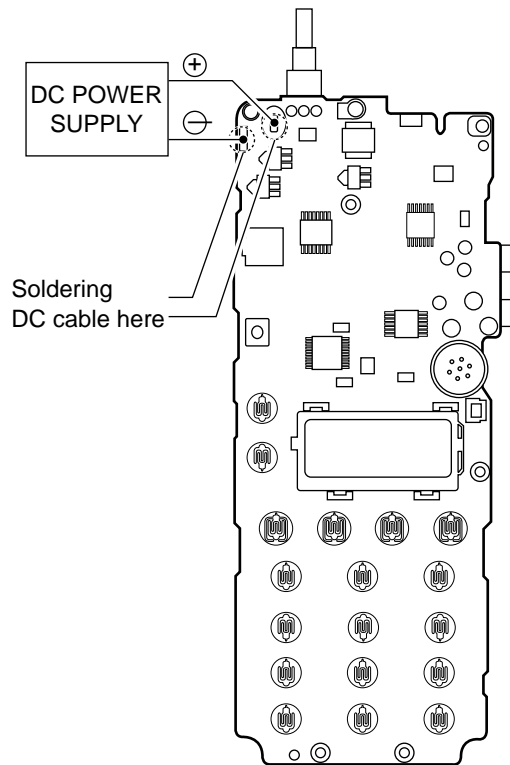

Top view

5-2 PLL ADJUSTMENT

ADJUSTMENT	ADJUSTMENT CONDITIONS	MEASUREMENT		VALUE	ADJUSTMENT	
		UNIT	LOCATION		UNIT	ADJUST
PLL LOCK VOLTAGE	1 <ul style="list-style-type: none"> • Operating frequency : 145.000 MHz • Receiving 	MAIN	Connect a digital multi meter to check point LV.	2.7 V	MAIN	L33

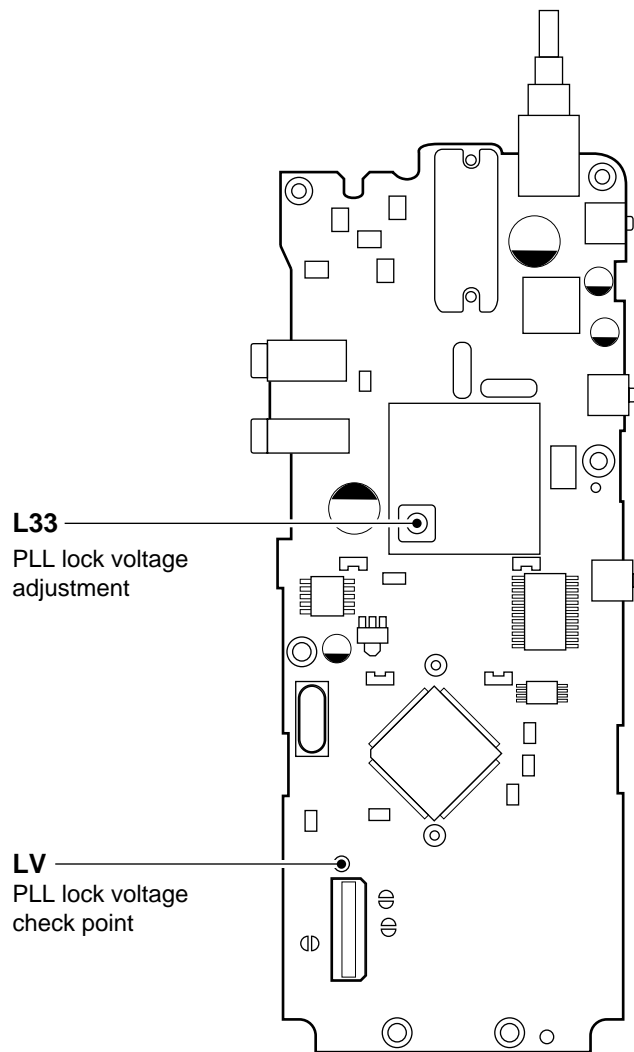

Bottom view

SECTION 6 PARTS LIST

[MAIN UNIT]

REF NO.	ORDER NO.	DESCRIPTION	
IC1	1130008350	S.IC	LV2105V-TLM
IC2	1110003490	S.IC	TA31136FN (D,EL)
IC3	1110005340	S.IC	NJM12902V-TE1
IC4	1130008090	S.IC	BU4066BCFV-E1
IC5	1110001810	S.IC	TA7368F (TP1)
IC7	1130010490	S.IC	BR24C16FV-E2
IC8	1140009920	S.IC	HD6433876B49H
IC10	1190000350	S.IC	M62363FP-650C
IC11	1130009110	S.IC	S-80942ANMP-DD6-T2
IC12	1180000800	S.IC	S-81350HG-KD-T1
Q1	1560001150	S.FET	2SK3476 (TE12L)
Q2	1560001160	S.FET	2SK3475 (TE12L)
Q3	1530003230	S.TRANSISTOR	2SC5085-Y (TE85R)
Q4	1530003220	S.TRANSISTOR	2SC4406-4-TL
Q5	1530003220	S.TRANSISTOR	2SC4406-4-TL
Q6	1530003220	S.TRANSISTOR	2SC4406-4-TL
Q11	1590001650	S.TRANSISTOR	XP4601 (TX)
Q12	1580000710	S.FET	3SK274 (TE85R)
Q13	1580000710	S.FET	3SK274 (TE85R)
Q14	1530003220	S.TRANSISTOR	2SC4406-4-TL
Q15	1520000450	S.TRANSISTOR	2SB1132 T100 Q
Q16	1590001190	S.TRANSISTOR	XP6501-(TX) .AB
Q17	1590001920	S.TRANSISTOR	UN911F (TX)
Q21	1510000510	S.TRANSISTOR	2SA1576A T106R
Q22	1510000510	S.TRANSISTOR	2SA1576A T106R
Q25	1530002690	S.TRANSISTOR	2SC4116-GR (TE85R)
Q31	1590000660	S.TRANSISTOR	DTC144TU T107
Q34	1560000810	S.FET	2SK1069-4-TL
Q37	1590000720	S.TRANSISTOR	DTA144EUA T106
Q38	1590000430	S.TRANSISTOR	DTC144EUA T106
Q43	1590000430	S.TRANSISTOR	DTC144EUA T106
Q50	1590001530	S.TRANSISTOR	UMX5 TL
Q51	1590000430	S.TRANSISTOR	DTC144EUA T106
Q53	1590001650	S.TRANSISTOR	XP4601 (TX)
Q54	1510000510	S.TRANSISTOR	2SA1576A T106R
Q55	1520000450	S.TRANSISTOR	2SB1132 T100 Q
Q56	1590001470	S.TRANSISTOR	UN9213 (TX)
Q57	1590001170	S.TRANSISTOR	XP1501-(TX) .AB
Q58	1590001650	S.TRANSISTOR	XP4601 (TX)
Q59	1530002690	S.TRANSISTOR	2SC4116-GR (TE85R)
D1	1790000620	S.DIODE	MA77 (TX)
D2	1790000620	S.DIODE	MA77 (TX)
D3	1790000620	S.DIODE	MA77 (TX)
D4	1790000620	S.DIODE	MA77 (TX)
D7	1750000770	S.VARICAP	HVC376BTRF
D8	1790000620	S.DIODE	MA77 (TX)
D9	1720000780	S.VARICAP	HVU350B TRF
D11	1720000780	S.VARICAP	HVU350B TRF
D12	1720000780	S.VARICAP	HVU350B TRF
D27	1790001670	S.DIODE	RB706F-40T106
D32	1790001670	S.DIODE	RB706F-40T106
D33	1790001670	S.DIODE	RB706F-40T106
D34	1790000950	S.ZENER	MA8056-M (TX)
D37	1790001260	S.DIODE	MA2S077-(TX)
D38	1720000780	S.VARICAP	HVU350B TRF
D39	1790001250	S.DIODE	MA2S111-(TX)
D40	1790001250	S.DIODE	MA2S111-(TX)
D41	1790001250	S.DIODE	MA2S111-(TX)
D42	1790001250	S.DIODE	MA2S111-(TX)
D43	1790001250	S.DIODE	MA2S111-(TX)
D44	1790001250	S.DIODE	MA2S111-(TX)
D45	1790001250	S.DIODE	MA2S111-(TX)
D46	1790001250	S.DIODE	MA2S111-(TX)
D47	1790001250	S.DIODE	MA2S111-(TX)
D48	1790001250	S.DIODE	MA2S111-(TX)
D49	1790001250	S.DIODE	MA2S111-(TX)
D50	1790000660	S.DIODE	MA728 (TX)

[MAIN UNIT]

REF NO.	ORDER NO.	DESCRIPTION	
F11	2010002330	MONOLITH	FL-298 (21.700 MHz)
F12	2020001490	S.CERAMIC	SFPC450E-TC01
F13	2010002330	MONOLITH	FL-298 (21.700 MHz)
X1	6050010800	S.XTAL	CR-659 (21.25 MHz)
X2	6050010870	S.XTAL	CR-663 (9.200 MHz)
X3	6070000210	S.DISCRIMINATOR	CDBCA450CX24
L1	6200008260	S.COIL	0.30-1.7-8TL 60N
L2	6200008280	S.COIL	0.30-1.7-7TL 50N
L4	6200008280	S.COIL	0.30-1.7-7TL 50N
L5	6200008250	S.COIL	0.30-0.9-7TL 21N
L6	6200007710	S.COIL	LQN21A 27NJ04
L7	6200005260	S.COIL	LL1608-F68NK
L8	6200006980	S.COIL	ELJRE R10G-F
L14	6200007000	S.COIL	ELJRE 82NG-F
L15	6200008170	S.COIL	0.35-1.6-8TL 54N
L16	6200008260	S.COIL	0.30-1.7-8TL 60N
L18	6200008090	S.COIL	LQN21A 68NJ04
L19	6200002380	S.COIL	LQN 1A 56NJ04
L20	6200003280	S.COIL	NL 252018T-2R2J
L21	6200005740	S.COIL	ELJRE 47NG-F
L24	6200003090	S.COIL	NL 322522T-2R7J-3
L26	6200003590	S.COIL	EXCCL3225U1
L29	6200006670	S.COIL	ELJRE 68NG-F
L32	6200008700	S.COIL	0.30-0.9-6TR 17.5N
L33	6130002480	S.COIL	LB-277
L34	6200003710	S.COIL	NL 252018T-2R7J
L36	6200004920	S.COIL	MLF1608A 2R2K-T
R1	7030003670	S.RESISTOR	ERJ3GEYJ 823 V (82 kΩ)
R2	7030003480	S.RESISTOR	ERJ3GEYJ 222 V (2.2 kΩ)
R3	7030003480	S.RESISTOR	ERJ3GEYJ 222 V (2.2 kΩ)
R5	7030003240	S.RESISTOR	ERJ3GEYJ 220 V (22 Ω)
R7	7030003360	S.RESISTOR	ERJ3GEYJ 221 V (220 Ω)
R10	7030003260	S.RESISTOR	ERJ3GEYJ 330 V (33 Ω)
R11	7030003500	S.RESISTOR	ERJ3GEYJ 332 V (3.3 kΩ)
R12	7030003500	S.RESISTOR	ERJ3GEYJ 332 V (3.3 kΩ)
R13	7030003260	S.RESISTOR	ERJ3GEYJ 330 V (33 Ω)
R14	7030003520	S.RESISTOR	ERJ3GEYJ 472 V (4.7 kΩ)
R15	7030003320	S.RESISTOR	ERJ3GEYJ 101 V (100 Ω)
R16	7030003220	S.RESISTOR	ERJ3GEYJ 150 V (15 Ω)
R17	7030003440	S.RESISTOR	ERJ3GEYJ 102 V (1 kΩ)
R18	7030003630	S.RESISTOR	ERJ3GEYJ 393 V (39 kΩ)
R19	7030003380	S.RESISTOR	ERJ3GEYJ 331 V (330 Ω)
R20	7030003710	S.RESISTOR	ERJ3GEYJ 184 V (180 kΩ)
R21	7030003440	S.RESISTOR	ERJ3GEYJ 102 V (1 kΩ)
R22	7030003660	S.RESISTOR	ERJ3GEYJ 683 V (68 kΩ)
R23	7030003420	S.RESISTOR	ERJ3GEYJ 681 V (680 Ω)
R30	7030003520	S.RESISTOR	ERJ3GEYJ 472 V (4.7 kΩ)
R32	7030003390	S.RESISTOR	ERJ3GEYJ 391 V (390 Ω)
R33	7030003380	S.RESISTOR	ERJ3GEYJ 331 V (330 Ω)
R35	7030003320	S.RESISTOR	ERJ3GEYJ 101 V (100 Ω)
R41	7030003320	S.RESISTOR	ERJ3GEYJ 101 V (100 Ω)
R44	7030003560	S.RESISTOR	ERJ3GEYJ 103 V (10 kΩ)
R48	7030003560	S.RESISTOR	ERJ3GEYJ 103 V (10 kΩ)
R49	7030003640	S.RESISTOR	ERJ3GEYJ 473 V (47 kΩ)
R50	7030003760	S.RESISTOR	ERJ3GEYJ 474 V (470 kΩ)
R52	7030003680	S.RESISTOR	ERJ3GEYJ 104 V (100 kΩ)
R53	7030003560	S.RESISTOR	ERJ3GEYJ 103 V (10 kΩ)
R54	7030003710	S.RESISTOR	ERJ3GEYJ 184 V (180 kΩ)
R57	7030003680	S.RESISTOR	ERJ3GEYJ 104 V (100 kΩ)
R58	7030003680	S.RESISTOR	ERJ3GEYJ 104 V (100 kΩ)
R59	7030003330	S.RESISTOR	ERJ3GEYJ 121 V (120 Ω)
R61	7030003280	S.RESISTOR	ERJ3GEYJ 470 V (47 Ω)
R64	7030003680	S.RESISTOR	ERJ3GEYJ 104 V (100 kΩ)
R65	7030003680	S.RESISTOR	ERJ3GEYJ 104 V (100 kΩ)
R66	7030003680	S.RESISTOR	ERJ3GEYJ 104 V (100 kΩ)
R67	7030003680	S.RESISTOR	ERJ3GEYJ 104 V (100 kΩ)
R68	7030003520	S.RESISTOR	ERJ3GEYJ 472 V (4.7 kΩ)
R69	7030003320	S.RESISTOR	ERJ3GEYJ 101 V (100 Ω)
R70	7030003680	S.RESISTOR	ERJ3GEYJ 104 V (100 kΩ)

S.=Surface mount

[MAIN UNIT]

REF NO.	ORDER NO.	DESCRIPTION
R72	7030003560	S.RESISTOR ERJ3GEYJ 103 V (10 kΩ)
R75	7030003360	S.RESISTOR ERJ3GEYJ 221 V (220 Ω)
R77	7030003320	S.RESISTOR ERJ3GEYJ 101 V (100 Ω)
R79	7030003440	S.RESISTOR ERJ3GEYJ 102 V (1 kΩ)
R80	7030003670	S.RESISTOR ERJ3GEYJ 823 V (82 kΩ)
R81	7030003400	S.RESISTOR ERJ3GEYJ 471 V (470 Ω)
R82	7030003470	S.RESISTOR ERJ3GEYJ 182 V (1.8 kΩ)
R83	7030003400	S.RESISTOR ERJ3GEYJ 471 V (470 Ω)
R84	7030003390	S.RESISTOR ERJ3GEYJ 391 V (390 Ω)
R85	7030003460	S.RESISTOR ERJ3GEYJ 152 V (1.5 kΩ)
R86	7030003640	S.RESISTOR ERJ3GEYJ 473 V (47 kΩ)
R87	7030003480	S.RESISTOR ERJ3GEYJ 222 V (2.2 kΩ)
R88	7030003620	S.RESISTOR ERJ3GEYJ 333 V (33 kΩ)
R93	7030003610	S.RESISTOR ERJ3GEYJ 273 V (27 kΩ)
R94	7030003800	S.RESISTOR ERJ3GEYJ 105 V (1 MΩ)
R95	7030003820	S.RESISTOR ERJ3GEYJ 155 V (1.5 MΩ)
R97	7030003720	S.RESISTOR ERJ3GEYJ 224 V (220 kΩ)
R98	7030003740	S.RESISTOR ERJ3GEYJ 334 V (330 kΩ)
R99	7030003690	S.RESISTOR ERJ3GEYJ 124 V (120 kΩ)
R100	7030003590	S.RESISTOR ERJ3GEYJ 183 V (18 kΩ)
R101	7030003800	S.RESISTOR ERJ3GEYJ 105 V (1 MΩ)
R102	7030003200	S.RESISTOR ERJ3GEYJ 100 V (10 Ω)
R103	7030003570	S.RESISTOR ERJ3GEYJ 123 V (12 kΩ)
R104	7030003680	S.RESISTOR ERJ3GEYJ 104 V (100 kΩ)
R105	7030003400	S.RESISTOR ERJ3GEYJ 471 V (470 Ω)
R107	7030003700	S.RESISTOR ERJ3GEYJ 154 V (150 kΩ)
R108	7030003700	S.RESISTOR ERJ3GEYJ 154 V (150 kΩ)
R112	7030003800	S.RESISTOR ERJ3GEYJ 105 V (1 MΩ)
R113	7030003660	S.RESISTOR ERJ3GEYJ 683 V (68 kΩ)
R114	7030003590	S.RESISTOR ERJ3GEYJ 183 V (18 kΩ)
R115	7030003690	S.RESISTOR ERJ3GEYJ 124 V (120 kΩ)
R117	7030003460	S.RESISTOR ERJ3GEYJ 152 V (1.5 kΩ)
R120	7030003640	S.RESISTOR ERJ3GEYJ 473 V (47 kΩ)
R121	7030003440	S.RESISTOR ERJ3GEYJ 102 V (1 kΩ)
R122	7030003490	S.RESISTOR ERJ3GEYJ 272 V (2.7 kΩ)
R123	7030003540	S.RESISTOR ERJ3GEYJ 682 V (6.8 kΩ)
R126	7030003640	S.RESISTOR ERJ3GEYJ 473 V (47 kΩ)
R127	7030003260	S.RESISTOR ERJ3GEYJ 330 V (33 Ω)
R128	7030003200	S.RESISTOR ERJ3GEYJ 100 V (10 Ω)
R130	7030003680	S.RESISTOR ERJ3GEYJ 104 V (100 kΩ)
R131	7030003400	S.RESISTOR ERJ3GEYJ 471 V (470 Ω)
R132	7030003400	S.RESISTOR ERJ3GEYJ 471 V (470 Ω)
R136	7030003320	S.RESISTOR ERJ3GEYJ 101 V (100 Ω)
R137	7030003320	S.RESISTOR ERJ3GEYJ 101 V (100 Ω)
R139	7030003560	S.RESISTOR ERJ3GEYJ 103 V (10 kΩ)
R141	7030003520	S.RESISTOR ERJ3GEYJ 472 V (4.7 kΩ)
R144	7030003600	S.RESISTOR ERJ3GEYJ 223 V (22 kΩ)
R145	7030003760	S.RESISTOR ERJ3GEYJ 474 V (470 kΩ)
R148	7030003680	S.RESISTOR ERJ3GEYJ 104 V (100 kΩ)
R150	7030003400	S.RESISTOR ERJ3GEYJ 471 V (470 Ω)
R155	7030003320	S.RESISTOR ERJ3GEYJ 101 V (100 Ω)
R159	7030003680	S.RESISTOR ERJ3GEYJ 104 V (100 kΩ)
R160	7030003340	S.RESISTOR ERJ3GEYJ 151 V (150 Ω)
R161	7030003600	S.RESISTOR ERJ3GEYJ 223 V (22 kΩ)
R162	7030003600	S.RESISTOR ERJ3GEYJ 223 V (22 kΩ)
R163	7030003480	S.RESISTOR ERJ3GEYJ 222 V (2.2 kΩ)
R164	7030003680	S.RESISTOR ERJ3GEYJ 104 V (100 kΩ)
R169	7030003630	S.RESISTOR ERJ3GEYJ 393 V (39 kΩ)
R170	7030003560	S.RESISTOR ERJ3GEYJ 103 V (10 kΩ)
R174	7030003580	S.RESISTOR ERJ3GEYJ 153 V (15 kΩ)
R176	7030003510	S.RESISTOR ERJ3GEYJ 392 V (3.9 kΩ)
R177	7030003440	S.RESISTOR ERJ3GEYJ 102 V (1 kΩ)
R178	7030003630	S.RESISTOR ERJ3GEYJ 393 V (39 kΩ)
R181	7030003940	S.RESISTOR ERJ3GEYF 104 V (100 kΩ)
R182	7510001280	S.THERMISTOR NTCCM20124AG473J-T
R184	7030003560	S.RESISTOR ERJ3GEYJ 103 V (10 kΩ)
R185	7030003440	S.RESISTOR ERJ3GEYJ 102 V (1 kΩ)
R186	7030003640	S.RESISTOR ERJ3GEYJ 473 V (47 kΩ)
R187	7030003680	S.RESISTOR ERJ3GEYJ 104 V (100 kΩ)
R193	7030003650	S.RESISTOR ERJ3GEYJ 563 V (56 kΩ)
R194	7030003650	S.RESISTOR ERJ3GEYJ 563 V (56 kΩ)
R195	7030003650	S.RESISTOR ERJ3GEYJ 563 V (56 kΩ)
R196	7030003670	S.RESISTOR ERJ3GEYJ 823 V (82 kΩ)
R204	7030003500	S.RESISTOR ERJ3GEYJ 332 V (3.3 kΩ)
R205	7030003460	S.RESISTOR ERJ3GEYJ 152 V (1.5 kΩ)
R210	7030003510	S.RESISTOR ERJ3GEYJ 392 V (3.9 kΩ)
R222	7030003590	S.RESISTOR ERJ3GEYJ 183 V (18 kΩ)
R224	7030003690	S.RESISTOR ERJ3GEYJ 124 V (120 kΩ)
R225	7030003680	S.RESISTOR ERJ3GEYJ 104 V (100 kΩ)
R226	7410000950	S.ARRAY EXB-V8V 102JV
R227	7030003570	S.RESISTOR ERJ3GEYJ 123 V (12 kΩ)

[MAIN UNIT]

REF NO.	ORDER NO.	DESCRIPTION
R228	7030003580	S.RESISTOR ERJ3GEYJ 153 V (15 kΩ)
R232	7030003440	S.RESISTOR ERJ3GEYJ 102 V (1 kΩ)
R235	7030003840	S.RESISTOR ERJ3GEYJ 225 V (2.2 MΩ)
R236	7410000950	S.ARRAY EXB-V8V 102JV
R237	7410000950	S.ARRAY EXB-V8V 102JV
R238	7410000950	S.ARRAY EXB-V8V 102JV
R239	7030003440	S.RESISTOR ERJ3GEYJ 102 V (1 kΩ)
R240	7030003440	S.RESISTOR ERJ3GEYJ 102 V (1 kΩ)
R241	7030003800	S.RESISTOR ERJ3GEYJ 105 V (1 MΩ)
R242	7030003800	S.RESISTOR ERJ3GEYJ 105 V (1 MΩ)
R243	7030003800	S.RESISTOR ERJ3GEYJ 105 V (1 MΩ)
R244	7030003680	S.RESISTOR ERJ3GEYJ 104 V (100 kΩ)
R245	7030003680	S.RESISTOR ERJ3GEYJ 104 V (100 kΩ)
R246	7030003680	S.RESISTOR ERJ3GEYJ 104 V (100 kΩ)
R251	7030003740	S.RESISTOR ERJ3GEYJ 334 V (330 kΩ)
R252	7030003560	S.RESISTOR ERJ3GEYJ 103 V (10 kΩ)
R257	7030004050	S.RESISTOR ERJ3GEYJ 1R0 V (1 Ω)
R259	7030003560	S.RESISTOR ERJ3GEYJ 103 V (10 kΩ)
R260	7030003560	S.RESISTOR ERJ3GEYJ 103 V (10 kΩ)
R261	7030003640	S.RESISTOR ERJ3GEYJ 473 V (47 kΩ)
R262	7030003420	S.RESISTOR ERJ3GEYJ 681 V (680 Ω)
R264	7030003660	S.RESISTOR ERJ3GEYJ 683 V (68 kΩ)
R266	7030003580	S.RESISTOR ERJ3GEYJ 153 V (15 kΩ)
R300	7030003560	S.RESISTOR ERJ3GEYJ 103 V (10 kΩ)
R301	7030003420	S.RESISTOR ERJ3GEYJ 103 V (10 kΩ)
R302	7030003560	S.RESISTOR ERJ3GEYJ 103 V (10 kΩ)
R303	7030003360	S.RESISTOR ERJ3GEYJ 221 V (220 Ω)
R304	7030003360	S.RESISTOR ERJ3GEYJ 221 V (220 Ω)
R305	7030003320	S.RESISTOR ERJ3GEYJ 101 V (100 Ω)
R306	7030003380	S.RESISTOR ERJ3GEYJ 331 V (330 Ω)
R307	7030003390	S.RESISTOR ERJ3GEYJ 391 V (390 Ω)
R308	7030003640	S.RESISTOR ERJ3GEYJ 473 V (47 kΩ)
R309	7030003550	S.RESISTOR ERJ3GEYJ 822 V (8.2 kΩ)
R310	7030003640	S.RESISTOR ERJ3GEYJ 473 V (47 kΩ)
R311	7030003640	S.RESISTOR ERJ3GEYJ 473 V (47 kΩ)
R313	7030003440	S.RESISTOR ERJ3GEYJ 102 V (1 kΩ)
R314	7030003520	S.RESISTOR ERJ3GEYJ 472 V (4.7 kΩ)
R315	7030003550	S.RESISTOR ERJ3GEYJ 822 V (8.2 kΩ)
R316	7030003520	S.RESISTOR ERJ3GEYJ 472 V (4.7 kΩ)
R318	7030003660	S.RESISTOR ERJ3GEYJ 683 V (68 kΩ)
R319	7030003660	S.RESISTOR ERJ3GEYJ 683 V (68 kΩ)
R320	7030003580	S.RESISTOR ERJ3GEYJ 153 V (15 kΩ)
R321	7030003560	S.RESISTOR ERJ3GEYJ 103 V (10 kΩ)
R323	7030003560	S.RESISTOR ERJ3GEYJ 103 V (10 kΩ)
R324	7030003450	S.RESISTOR ERJ3GEYJ 122 V (12 kΩ)
R325	7030003660	S.RESISTOR ERJ3GEYJ 683 V (68 kΩ)
R326	7030003660	S.RESISTOR ERJ3GEYJ 683 V (68 kΩ)
R327	7030003680	S.RESISTOR ERJ3GEYJ 104 V (100 kΩ)
R328	7030003680	S.RESISTOR ERJ3GEYJ 104 V (100 kΩ)
R329	7030003640	S.RESISTOR ERJ3GEYJ 473 V (47 kΩ)
R330	7030003560	S.RESISTOR ERJ3GEYJ 103 V (10 kΩ)
R331	7030003560	S.RESISTOR ERJ3GEYJ 103 V (10 kΩ)
R332	7030003520	S.RESISTOR ERJ3GEYJ 472 V (4.7 kΩ)
R333	7030003800	S.RESISTOR ERJ3GEYJ 105 V (1 MΩ)
R334	7030003800	S.RESISTOR ERJ3GEYJ 105 V (1 MΩ)
R335	7030003800	S.RESISTOR ERJ3GEYJ 105 V (1 MΩ)
R336	7030003680	S.RESISTOR ERJ3GEYJ 104 V (100 kΩ)
R337	7030003830	S.RESISTOR ERJ3GEYJ 185 V (1.8 MΩ)
R340	7030003600	S.RESISTOR ERJ3GEYJ 223 V (22 kΩ)
R341	7030003620	S.RESISTOR ERJ3GEYJ 333 V (33 kΩ)
R346	7030003680	S.RESISTOR ERJ3GEYJ 104 V (100 kΩ)
R348	7030003440	S.RESISTOR ERJ3GEYJ 102 V (1 kΩ)
R349	7030003680	S.RESISTOR ERJ3GEYJ 104 V (100 kΩ)
R350	7030003800	S.RESISTOR ERJ3GEYJ 105 V (1 MΩ)
R351	7030003310	S.RESISTOR ERJ3GEYJ 820 V (82 Ω)
R352	7030003730	S.RESISTOR ERJ3GEYJ 274 V (270 kΩ)
R353	7030003560	S.RESISTOR ERJ3GEYJ 103 V (10 kΩ)
R354	7030003480	S.RESISTOR ERJ3GEYJ 222 V (2.2 kΩ)
R355	7030003720	S.RESISTOR ERJ3GEYJ 224 V (220 kΩ)
R356	7030003320	S.RESISTOR ERJ3GEYJ 101 V (100 Ω)
R357	7030003620	S.RESISTOR ERJ3GEYJ 333 V (33 kΩ)
R358	7030003620	S.RESISTOR ERJ3GEYJ 333 V (33 kΩ)
R359	7030003800	S.RESISTOR ERJ3GEYJ 105 V (1 MΩ)
R360	7030003490	S.RESISTOR ERJ3GEYJ 272 V (2.7 kΩ)
R361	7030003800	S.RESISTOR ERJ3GEYJ 105 V (1 MΩ)
R362	7030003560	S.RESISTOR ERJ3GEYJ 103 V (10 kΩ)

S.=Surface mount

[MAIN UNIT]

REF NO.	ORDER NO.	DESCRIPTION
C1	4030007020	S.CERAMIC C1608 CH 1H 120J-T-A
C2	4030009550	S.CERAMIC C1608 CH 1H 2R5B-T-A
C3	4030007060	S.CERAMIC C1608 CH 1H 270J-T-A
C4	4030006970	S.CERAMIC C1608 CH 1H 060D-T-A
C5	4030007050	S.CERAMIC C1608 CH 1H 220J-T-A
C8	4030006860	S.CERAMIC C1608 JB 1H 102K-T-A
C10	4030006860	S.CERAMIC C1608 JB 1H 102K-T-A
C13	4030006860	S.CERAMIC C1608 JB 1H 102K-T-A
C14	4030006900	S.CERAMIC C1608 JB 1E 103K-T-A
C15	4030007150	S.CERAMIC C1608 CH 1H 151J-T-A
C17	4030006860	S.CERAMIC C1608 JB 1H 102K-T-A
C18	4030006860	S.CERAMIC C1608 JB 1H 102K-T-A
C19	4030006900	S.CERAMIC C1608 JB 1E 103K-T-A
C20	4030006860	S.CERAMIC C1608 JB 1H 102K-T-A
C21	4550006480	S.TANTALUM TEMSVA 1C 475M-8L
C22	4030007130	S.CERAMIC C1608 CH 1H 101J-T-A
C23	4030006860	S.CERAMIC C1608 JB 1H 102K-T-A
C24	4030006860	S.CERAMIC C1608 JB 1H 102K-T-A
C25	4030006860	S.CERAMIC C1608 JB 1H 102K-T-A
C26	4030006860	S.CERAMIC C1608 JB 1H 102K-T-A
C27	4030007040	S.CERAMIC C1608 CH 1H 180J-T-A
C28	4030007020	S.CERAMIC C1608 CH 1H 120J-T-A
C29	4030006860	S.CERAMIC C1608 JB 1H 102K-T-A
C30	4030007050	S.CERAMIC C1608 CH 1H 220J-T-A
C31	4030006960	S.CERAMIC C1608 CH 1H 050C-T-A
C32	4030006860	S.CERAMIC C1608 JB 1H 102K-T-A
C33	4030006860	S.CERAMIC C1608 JB 1H 102K-T-A
C47	4550006260	S.TANTALUM TESVSP 1C 474M-8R
C48	4550005980	S.TANTALUM TEMSVA 1A 475M-8L
C50	4550003080	S.TANTALUM TEMSVA 1A 335M-8L
C52	4030007030	S.CERAMIC C1608 CH 1H 150J-T-A
C54	4030006860	S.CERAMIC C1608 JB 1H 102K-T-A
C55	4030006900	S.CERAMIC C1608 JB 1E 103K-T-A
C60	4030006860	S.CERAMIC C1608 JB 1H 102K-T-A
C61	4030007020	S.CERAMIC C1608 CH 1H 120J-T-A
C62	4030007000	S.CERAMIC C1608 CH 1H 090D-T-A
C64	4030006990	S.CERAMIC C1608 CH 1H 080D-T-A
C69	4030007110	S.CERAMIC C1608 CH 1H 680J-T-A
C70	4030006860	S.CERAMIC C1608 JB 1H 102K-T-A
C72	4550000460	S.TANTALUM TESVA 1C 105M1-8L
C73	4030011600	S.CERAMIC C1608 JB 1C 104KT-N
C75	4030011600	S.CERAMIC C1608 JB 1C 104KT-N
C76	4030007040	S.CERAMIC C1608 CH 1H 180J-T-A
C79	4030006960	S.CERAMIC C1608 CH 1H 050C-T-A
C80	4030009510	S.CERAMIC C1608 CH 1H 010B-T-A
C81	4030007130	S.CERAMIC C1608 CH 1H 101J-T-A
C82	4030006860	S.CERAMIC C1608 JB 1H 102K-T-A
C87	4030006900	S.CERAMIC C1608 JB 1E 103K-T-A
C88	4030006860	S.CERAMIC C1608 JB 1H 102K-T-A
C89	4030006860	S.CERAMIC C1608 JB 1H 102K-T-A
C90	4030006860	S.CERAMIC C1608 JB 1H 102K-T-A
C91	4030006930	S.CERAMIC C1608 CH 1H 020C-T-A
C92	4030007130	S.CERAMIC C1608 CH 1H 101J-T-A
C93	4030006860	S.CERAMIC C1608 JB 1H 102K-T-A
C94	4030009500	S.CERAMIC C1608 CH 1H 0R5B-T-A
C95	4030006860	S.CERAMIC C1608 JB 1H 102K-T-A
C96	4030007130	S.CERAMIC C1608 CH 1H 101J-T-A
C97	4030006960	S.CERAMIC C1608 CH 1H 050C-T-A
C98	4030006960	S.CERAMIC C1608 CH 1H 050C-T-A
C99	4030006860	S.CERAMIC C1608 JB 1H 102K-T-A
C100	4030007080	S.CERAMIC C1608 CH 1H 390J-T-A
C101	4030007100	S.CERAMIC C1608 CH 1H 560J-T-A
C102	4030007100	S.CERAMIC C1608 CH 1H 560J-T-A
C104	4030006860	S.CERAMIC C1608 JB 1H 102K-T-A
C105	4030006900	S.CERAMIC C1608 JB 1E 103K-T-A
C106	4030007050	S.CERAMIC C1608 CH 1H 220J-T-A
C107	4030006860	S.CERAMIC C1608 JB 1H 102K-T-A
C108	4030006900	S.CERAMIC C1608 JB 1E 103K-T-A
C110	4030006960	S.CERAMIC C1608 CH 1H 050C-T-A
C111	4030006900	S.CERAMIC C1608 JB 1E 103K-T-A
C112	4030006860	S.CERAMIC C1608 JB 1H 102K-T-A
C113	4030006860	S.CERAMIC C1608 JB 1H 102K-T-A
C114	4030008900	S.CERAMIC C1608 JB 1C 333K-T-A
C115	4030006900	S.CERAMIC C1608 JB 1E 103K-T-A
C116	4030007120	S.CERAMIC C1608 CH 1H 820J-T-A
C117	4030006860	S.CERAMIC C1608 JB 1H 102K-T-A
C118	4030006900	S.CERAMIC C1608 JB 1E 103K-T-A
C119	4030008680	S.CERAMIC C2012 JF 1C 105Z-T-A
C120	4030011600	S.CERAMIC C1608 JB 1C 104KT-N
C121	4030007170	S.CERAMIC C1608 CH 1H 221J-T-A
C122	4030007170	S.CERAMIC C1608 CH 1H 221J-T-A
C123	4030006860	S.CERAMIC C1608 JB 1H 102K-T-A

[MAIN UNIT]

REF NO.	ORDER NO.	DESCRIPTION
C124	4030006900	S.CERAMIC C1608 JB 1E 103K-T-A
C125	4030006870	S.CERAMIC C1608 JB 1H 222K-T-A
C126	4030008470	S.CERAMIC C1608 JB 1H 272K-T-A
C128	4030011600	S.CERAMIC C1608 JB 1C 104KT-N
C129	4550002960	S.TANTALUM TESVA 1C 155M1-8L
C131	4030006900	S.CERAMIC C1608 JB 1E 103K-T-A
C132	4030008770	S.CERAMIC C1608 JB 1H 562K-T-A
C133	4030011600	S.CERAMIC C1608 JB 1C 104KT-N
C134	4030007170	S.CERAMIC C1608 CH 1H 221J-T-A
C135	4030011280	S.CERAMIC C1608 CH 1H 271J-T-A
C136	4030008770	S.CERAMIC C1608 JB 1H 562K-T-A
C137	4030008900	S.CERAMIC C1608 JB 1C 333K-T-A
C138	4030006860	S.CERAMIC C1608 JB 1H 102K-T-A
C139	4030008680	S.CERAMIC C2012 JF 1C 105Z-T-A
C140	4030011600	S.CERAMIC C1608 JB 1C 104KT-N
C144	4030006860	S.CERAMIC C1608 JB 1H 102K-T-A
C145	4510004630	S.ELECTROLYTIC ECEV1CA100SR
C147	4030008920	S.CERAMIC C1608 JB 1C 473K-T-A
C149	4030008880	S.CERAMIC C1608 JB 1C 223K-T-A
C150	4550006050	S.TANTALUM TEMSVA 0J 106M8L
C151	4030007090	S.CERAMIC C1608 CH 1H 470J-T-A
C152	4030008920	S.CERAMIC C1608 JB 1C 473K-T-A
C153	4510006940	S.ELECTROLYTIC EEVFC0J101P
C154	4550006250	S.TANTALUM TEMSVA 1A 106M-8L
C161	4030006900	S.CERAMIC C1608 JB 1E 103K-T-A
C162	4030006900	S.CERAMIC C1608 JB 1E 103K-T-A
C163	4030006860	S.CERAMIC C1608 JB 1H 102K-T-A
C164	4030006860	S.CERAMIC C1608 JB 1C 102K-T-A
C165	4030006860	S.CERAMIC C1608 JB 1H 102K-T-A
C166	4030006860	S.CERAMIC C1608 JB 1H 102K-T-A
C167	4030007090	S.CERAMIC C1608 CH 1H 470J-T-A
C168	4030006860	S.CERAMIC C1608 JB 1H 102K-T-A
C169	4030006860	S.CERAMIC C1608 JB 1H 102K-T-A
C171	4030011600	S.CERAMIC C1608 JB 1C 104KT-N
C173	4510006220	S.ELECTROLYTIC ECEV1CA101UP
C174	4510005430	S.ELECTROLYTIC ECEV0JA220SR
C179	4030006900	S.CERAMIC C1608 JB 1E 103K-T-A
C193	4030006990	S.CERAMIC C1608 CH 1H 080D-T-A
C194	4030007030	S.CERAMIC C1608 CH 1H 150J-T-A
C195	4030007100	S.CERAMIC C1608 CH 1H 560J-T-A
C197	4030011600	S.CERAMIC C1608 JB 1C 104KT-N
C199	4030011600	S.CERAMIC C1608 JB 1C 104KT-N
C204	4030006860	S.CERAMIC C1608 JB 1H 102K-T-A
C205	4030006860	S.CERAMIC C1608 JB 1H 102K-T-A
C209	4030011600	S.CERAMIC C1608 JB 1C 104KT-N
C212	4030006900	S.CERAMIC C1608 JB 1E 103K-T-A
C213	4550002890	S.TANTALUM TESVA 1A 225M1-8L
C214	4030008900	S.CERAMIC C1608 JB 1C 333K-T-A
C216	4030008920	S.CERAMIC C1608 JB 1C 473K-T-A
C217	4030011600	S.CERAMIC C1608 JB 1C 104KT-N
C219	4030006900	S.CERAMIC C1608 JB 1E 103K-T-A
C223	4030006900	S.CERAMIC C1608 JB 1E 103K-T-A
C230	4030008890	S.CERAMIC C1608 JB 1C 273K-T-A
C232	4030008630	S.CERAMIC C1608 JF 1C 104Z-T-A
C233	4030006860	S.CERAMIC C1608 JB 1H 102K-T-A
C234	4030006860	S.CERAMIC C1608 JB 1H 102K-T-A
C236	4030006900	S.CERAMIC C1608 JB 1E 103K-T-A
C243	4030006860	S.CERAMIC C1608 JB 1H 102K-T-A
C244	4030006900	S.CERAMIC C1608 JB 1E 103K-T-A
C245	4030006900	S.CERAMIC C1608 JB 1E 103K-T-A
C249	4030006900	S.CERAMIC C1608 JB 1C 103K-T-A
C251	4030006860	S.CERAMIC C1608 JB 1H 102K-T-A
C252	4030006860	S.CERAMIC C1608 JB 1H 102K-T-A
C277	4030006970	S.CERAMIC C1608 CH 1H 060D-T-A
C278	4030007050	S.CERAMIC C1608 CH 1H 220J-T-A
C281	4030006860	S.CERAMIC C1608 JB 1H 102K-T-A
C282	4030006860	S.CERAMIC C1608 JB 1H 102K-T-A
C283	4030006870	S.CERAMIC C1608 JB 1H 222K-T-A
C284	4030007070	S.CERAMIC C1608 CH 1H 330J-T-A
C285	4030007040	S.CERAMIC C1608 CH 1H 180J-T-A
C287	4030007050	S.CERAMIC C1608 CH 1H 220J-T-A
C288	4030006860	S.CERAMIC C1608 JB 1H 102K-T-A
C289	4030006860	S.CERAMIC C1608 JB 1H 102K-T-A
C290	4030006860	S.CERAMIC C1608 JB 1H 102K-T-A
C293	4030011600	S.CERAMIC C1608 JB 1C 104KT-N
C295	4030006860	S.CERAMIC C1608 JB 1H 102K-T-A
C296	4030006860	S.CERAMIC C1608 JB 1H 102K-T-A
C297	4030006860	S.CERAMIC C1608 JB 1H 102K-T-A
C298	4550005980	S.TANTALUM TEMSVA 1A 475M-8L
C299	4030006850	S.CERAMIC C1608 JB 1H 471K-T-A
C300	4030006860	S.CERAMIC C1608 JB 1H 102K-T-A
C301	4030006860	S.CERAMIC C1608 JB 1H 102K-T-A

S.=Surface mount

[MAIN UNIT]

REF NO.	ORDER NO.	DESCRIPTION	
C303	4030006860	S.CERAMIC	C1608 JB 1H 102K-T-A
C304	4030008920	S.CERAMIC	C1608 JB 1C 473K-T-A
C305	4030006850	S.CERAMIC	C1608 JB 1H 471K-T-A
C356	4030006860	S.CERAMIC	C1608 JB 1H 102K-T-A
C357	4030006860	S.CERAMIC	C1608 JB 1H 102K-T-A
C358	4030006860	S.CERAMIC	C1608 JB 1H 102K-T-A
C360	4030006860	S.CERAMIC	C1608 JB 1H 102K-T-A
C361	4030006860	S.CERAMIC	C1608 JB 1H 102K-T-A
C363	4030006860	S.CERAMIC	C1608 JB 1H 102K-T-A
C364	4030007060	S.CERAMIC	C1608 CH 1H 270J-T-A
C365	4030009560	S.CERAMIC	C1608 CH 1H R75B-T-A
C367	4030009500	S.CERAMIC	C1608 CH 1H 0R5B-T-A
C368	4030009500	S.CERAMIC	C1608 CH 1H 0R5B-T-A
C369	4030008900	S.CERAMIC	C1608 JB 1C 333K-T-A
C370	4030009970	S.CERAMIC	C1608 JB 1H 182K-T-A
C372	4030008880	S.CERAMIC	C1608 JB 1C 223K-T-A
C373	4030009880	S.CERAMIC	C1608 JB 1H 682K-T-A
C374	4030006870	S.CERAMIC	C1608 JB 1H 222K-T-A
C375	4030006860	S.CERAMIC	C1608 JB 1H 102K-T-A
C376	4030006860	S.CERAMIC	C1608 JB 1H 102K-T-A
C377	4550006350	S.TANTALUM	TEMSVB2 1A 226M-8L
C378	4030011600	S.CERAMIC	C1608 JB 1C 104KT-N
C379	4030006860	S.CERAMIC	C1608 JB 1H 102K-T-A
C380	4510005430	S.ELECTROLYTIC	ECEV0JA220SR
C381	4550006250	S.TANTALUM	TEMSVA 1A 106M-8L
C385	4030011600	S.CERAMIC	C1608 JB 1C 104KT-N
C386	4030007050	S.CERAMIC	C1608 CH 1H 220J-T-A
C387	4030007090	S.CERAMIC	C1608 CH 1H 470J-T-A
C388	4030007050	S.CERAMIC	C1608 CH 1H 220J-T-A
C389	4030006860	S.CERAMIC	C1608 JB 1H 102K-T-A
C390	4030007060	S.CERAMIC	C1608 CH 1H 270J-T-A
C391	4030007050	S.CERAMIC	C1608 CH 1H 220J-T-A
C392	4550006250	S.TANTALUM	TEMSVA 1A 106M-8L
C393	4550006760	S.TANTALUM	TEMSVB2 1A 336M-8R
C394	4030011600	S.CERAMIC	C1608 JB 1C 104KT-N
C395	4030007040	S.CERAMIC	C1608 CH 1H 180J-T-A
C396	4030007070	S.CERAMIC	C1608 CH 1H 330J-T-A
C397	4030006950	S.CERAMIC	C1608 CH 1H 040C-T-A
C398	4550005980	S.TANTALUM	TEMSVA 1A 475M-8L
C399	4030008650	S.CERAMIC	C1608 JB 1H 332K-T-A
C400	4030006870	S.CERAMIC	C1608 JB 1H 222K-T-A
J2	6450001680	CONNECTOR	HSJ1122-010010
J3	6450001690	CONNECTOR	HSJ1456-01-220
J5	6510018430	S.CONNECTOR	AXN330C038P
J6	6510021900	S.CONNECTOR	BM02B-ASRS-TF
DS1	5030002000	LCD	TTR5515 UPFDHW
DS2	5010000160	S.LED	LNJ310M6URA
DS3	5010000160	S.LED	LNJ310M6URA
MC1	7700002160	MICROPHON	KUC3523-040245
S1	2230001070	S.SWITCH	JPM1990-2711R
S2	2230001070	S.SWITCH	JPM1990-2711R
S3	2230001070	S.SWITCH	JPM1990-2711R
S801	7600000210	ENCODER	TP70N00E20-15F-1903
W7	7030003860	S.JUMPER	ERJ3GE JPW V
W8	7030003860	S.JUMPER	ERJ3GE JPW V
W9	7030003860	S.JUMPER	ERJ3GE JPW V
W11	7030003860	S.JUMPER	ERJ3GE JPW V
W12	7030003860	S.JUMPER	ERJ3GE JPW V
W13	7030003860	S.JUMPER	ERJ3GE JPW V
EP1	0910053802	PCB	B 5649B
EP2	8930051310	LCD CONTACT	SRCN-2251-SP-N-W
EP3	6910012350	S.BEAD	MMZ1608Y 102BT
EP4	6910012350	S.BEAD	MMZ1608Y 102BT
EP5	6910012350	S.BEAD	MMZ1608Y 102BT

S.=Surface mount

SECTION 7 MECHANICAL PARTS AND DISASSEMBLY

[CHASSIS PARTS]

REF. NO.	ODER NO.	DESCRIPTION	QTY.
J1	6510022460	Ant connector- BNC-R162	1
MP1	8210018250	2251 T-front panel (C)-1	1
MP2	8930050890	2251 terminal holder	1
MP3	8010017990	2251 chassis	1
MP4	8210016570	2251 rear panel	1
MP5	8930050870	2251 release button	1
MP7	8310051450	2251 window plate	1
MP8	8930051350	2251 jack rubber	1
MP9	8210016550	2251 jack panel	1
MP10	8610011080	Knob N-287	1
MP13	8930055520	2251 10key	1
MP14	8930050840	2251 minus terminal	1
MP15	8930050850	2251 plus terminal	1
MP20	8930042350	1922 mic sheet	1
MP21	8930051300	2251 mic sponge	1
MP22	8930051290	2251 opt sheet	1
MP23	8830001340	1903 hex nut	1
MP24	8930050900	2251 window sheet	1
MP25	8930036751	Spring	1
MP27	8830001250	Ant connector-101	1
MP31	8810009510	Screw BT M2 x 4 NI-ZU	8
MP32	8810009560	Screw BT M2 x 6 ZK	7
MP33	8810000100	Screw M2 x 4 ZK	4
MP37	8930050800	2251 jack cap	1
MP39	8860001210	2251 ANT rug	1
MP41	8510013570	2422 shield plate	1
SP1	2510001120	Speaker SDRS-3650P-008	1

[ACCESSORIES]

REF. NO.	ODER NO.	DESCRIPTION	QTY.
EP1	3310002840	Antenna FA-B2E	1
EP2	0880000840	Battery BP-208	1
MP1	8930042040	1922 Belt clip	1
MP2	8930051290	2251 OPT sheet	1

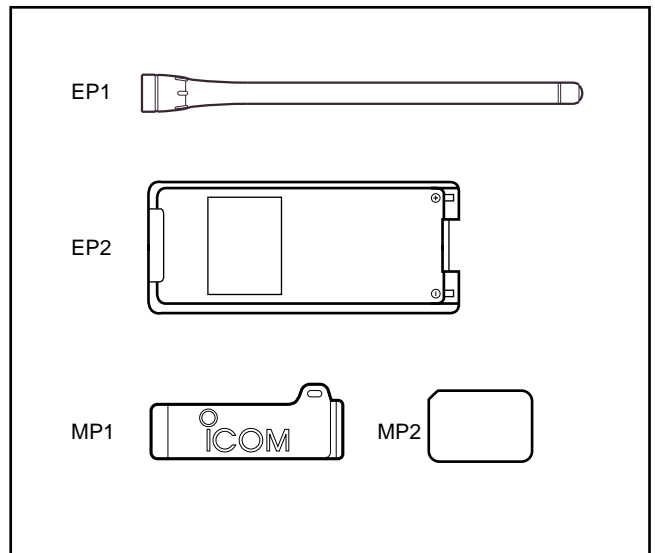

[MAIN UNIT]

REF. NO.	ODER NO.	DESCRIPTION	QTY.
DS1	8930051310	LCD TTR-5515	1
EP2	8930051310	LCD contact SRCN-2251-SP-N-W	1
MP1	8510011111	1922 VCO case-1	1
MP2	8510011101	1922 VCO cover-1	1
MP3	8930050811	2251 LCD holder-1	1
MP4	8210016580	2251 reflector	1
MP5	8410002410	2468 PA heatsink	1

Screw abbreviations BT: Self-tapping
 NI-ZU: Nickel-Zinc
 ZK: Black

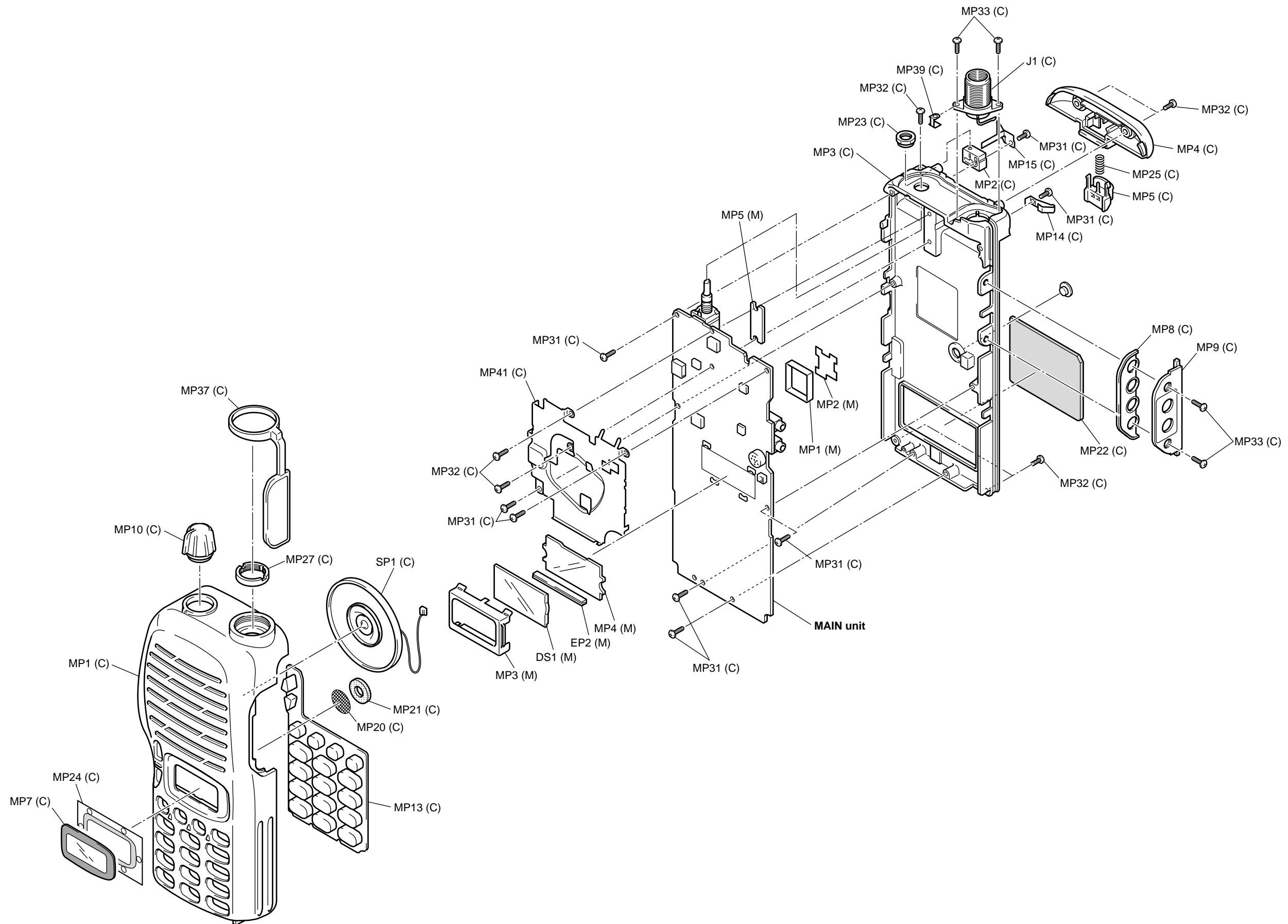

UNIT abbreviation (C): CHASSIS PARTS, (M): MAIN UNIT

SECTION 8 SEMI-CONDUCTOR INFORMATION

8 - 1 TRANSISTORS AND FETS

NAME	SYMBOL	INSIDE VIEW
2SA1576 R	FR	
2SB1132 Q	BAQ	
2SC4116 GR 2SC4406 4 2SC5085 Y	LG JT MCY	
2SK1069 4	FJ	
2SK3475	WB	
2SK3476	TUCF	
3SK274	UN	

NAME	SYMBOL	INSIDE VIEW
DTA144EU UN911F	16 6O	
DTC144EU UN9213	26 8C	
DTC144TU	06	
UMX5	X5	
XP1501 AB	5R	
XP4601	5C	
XP6501 AB	5N	

8 - 2 DIODES

NAME	SYMBOL	INSIDE VIEW
HVC376B	B9	
HVU350B	BO	
MA2S077 MA2S111 MA728	S A 2A	
MA77	4B	
MA8056-M	5-6	
RB706F	3J	

SECTION 9 BOARD LAYOUTS

9 - 1 MAIN UNIT

(TOP VIEW)

The combination of this page and the next page shows the unit layout in the same configuration as the actual P.C. Board.

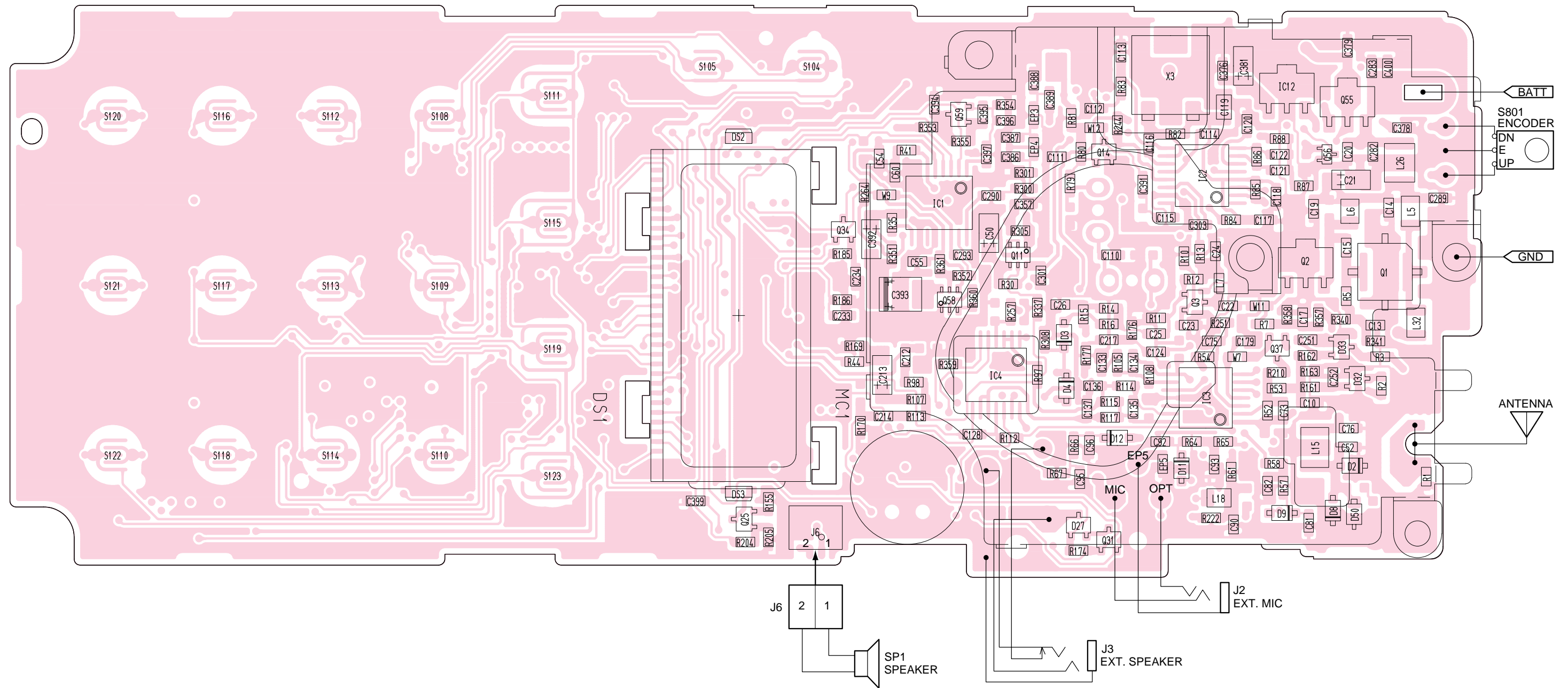

(BOTTOM VIEW)

The combination of this page and the previous page shows the unit layout in the same configuration as the actual P.C. Board.

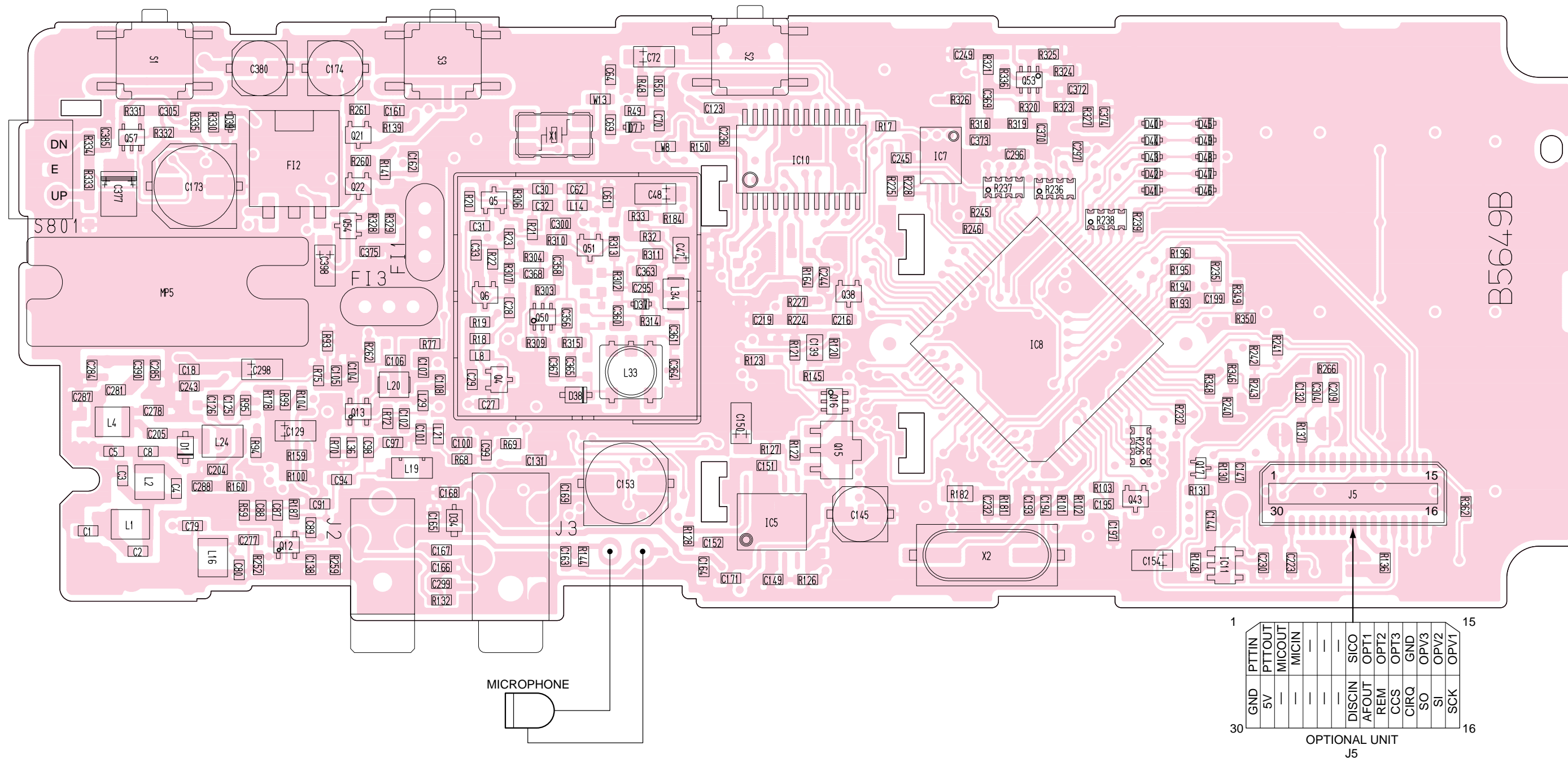

SECTION 10 BC-146 OPTIONAL DESKTOP CHARGER INFORMATION

10-1 PARTS LIST

[CHARGE UNIT]

REF. NO.	ODER NO.	DESCRIPTION	QTY.
R1	7010007550	RESISTOR ERG3SJ680H	1
R2	7010007100	RESISTOR PSD1/4V 1 kΩ	1
J1	6510021470	CONNECTOR HEC0470-01-230	1
DS1	5040001390	LED TLG124A	1
EP1	0910053820	PCB B 5650	1
MP1	8930051340	2338 TERMINAL	1
MP2	8930051340	2338 TERMINAL	1

[CHASSIS UNIT]

REF. NO.	ODER NO.	DESCRIPTION	QTY.
MP1	8010018620	2447 case (A)	1
MP2	8110007450	2447 cover	1
MP3	8930039620	Leg cushion (A)	4
MP4	8930055020	2480 spacer	1
MP5	8930055030	2480 BC-spacer	1
MP6	8810008660	Screw B0 M 3 x 8 NI-ZU (BT)	1

Screw abbreviations B0, BT:Self-tapping
NI-ZU :Nickel-Zinc

10-2 DISASSEMBLY INFORMATION

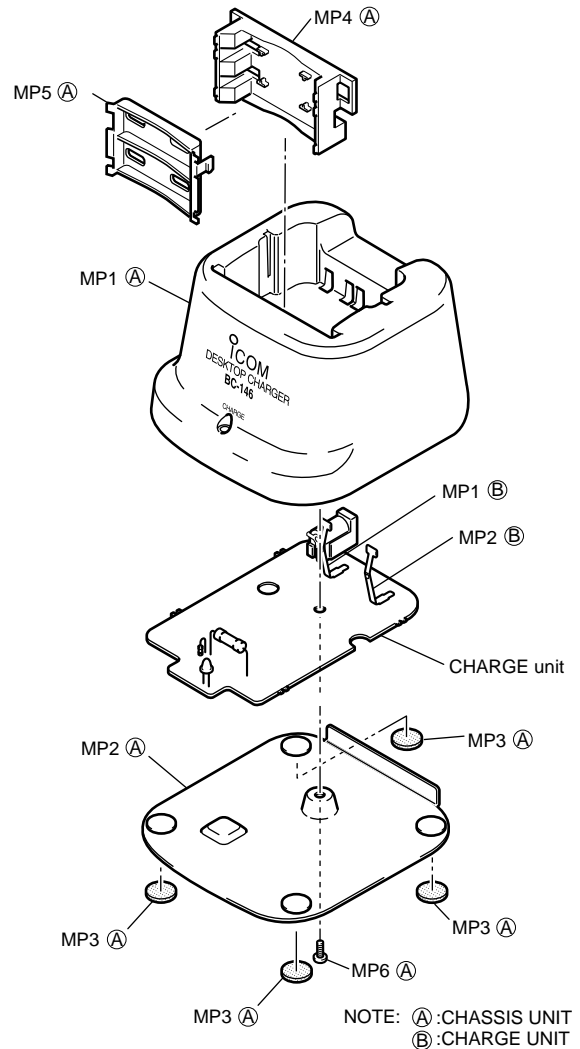

10-3 VOLTAGE DIAGRAM

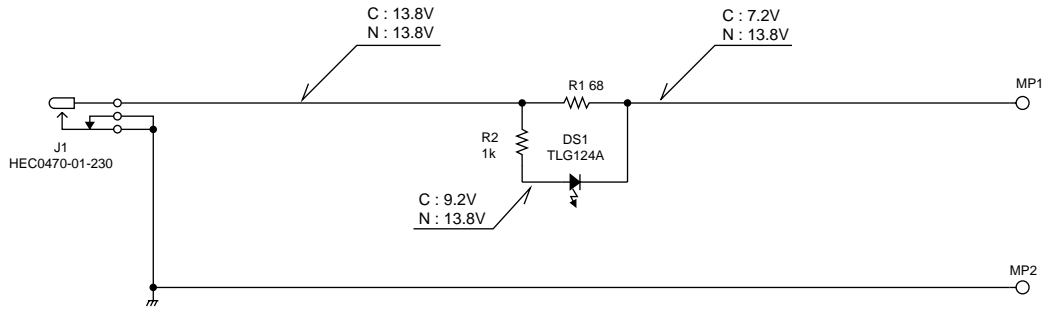

10-4 BOARD LAYOUT

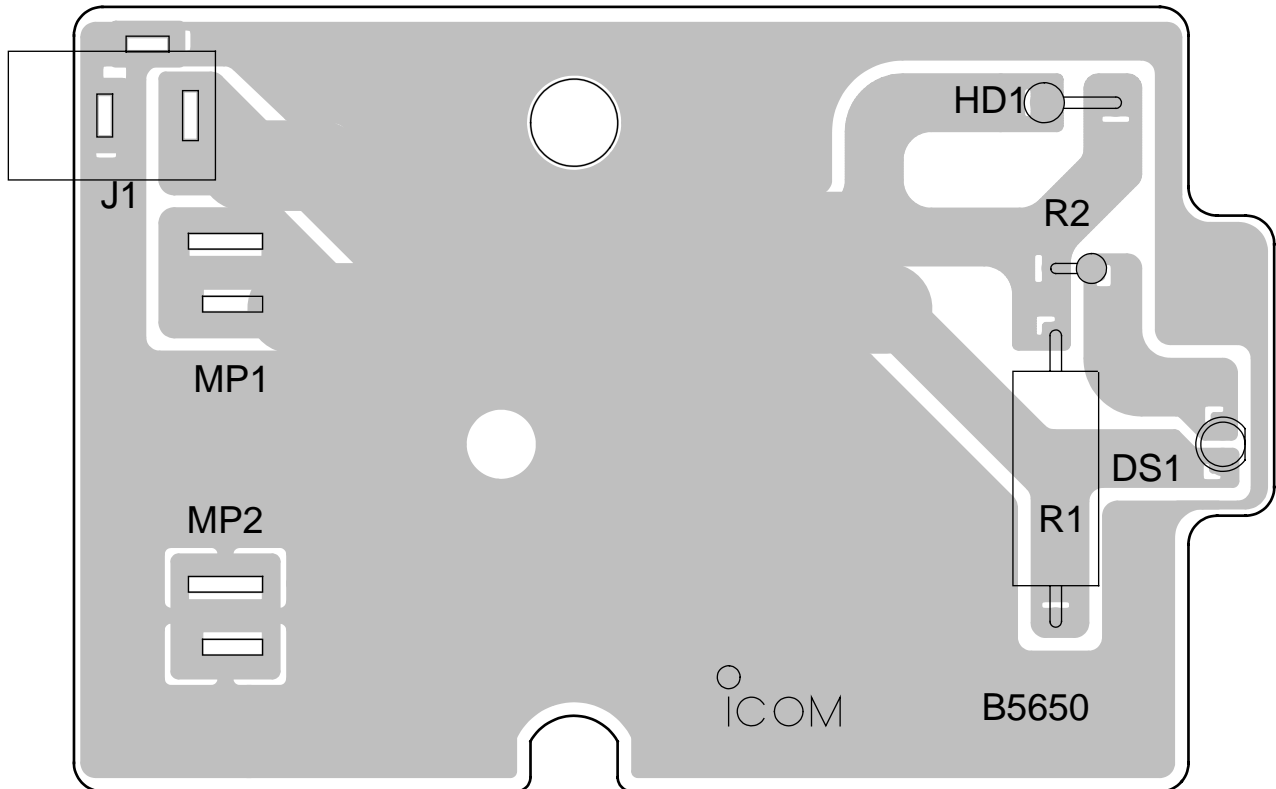

SECTION 11 BLOCK DIAGRAM

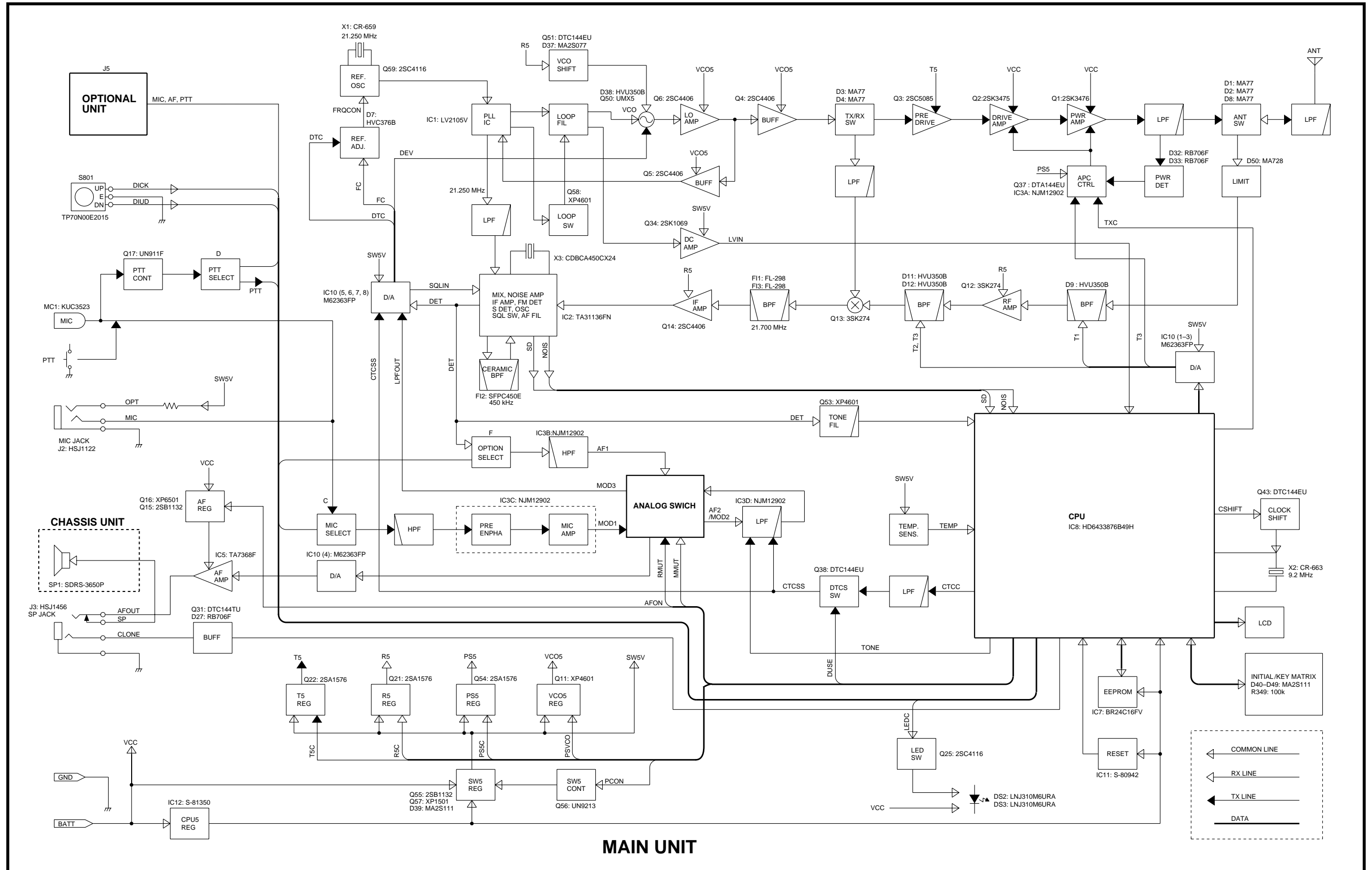

SECTION 12 VOLTAGE DIAGRAM

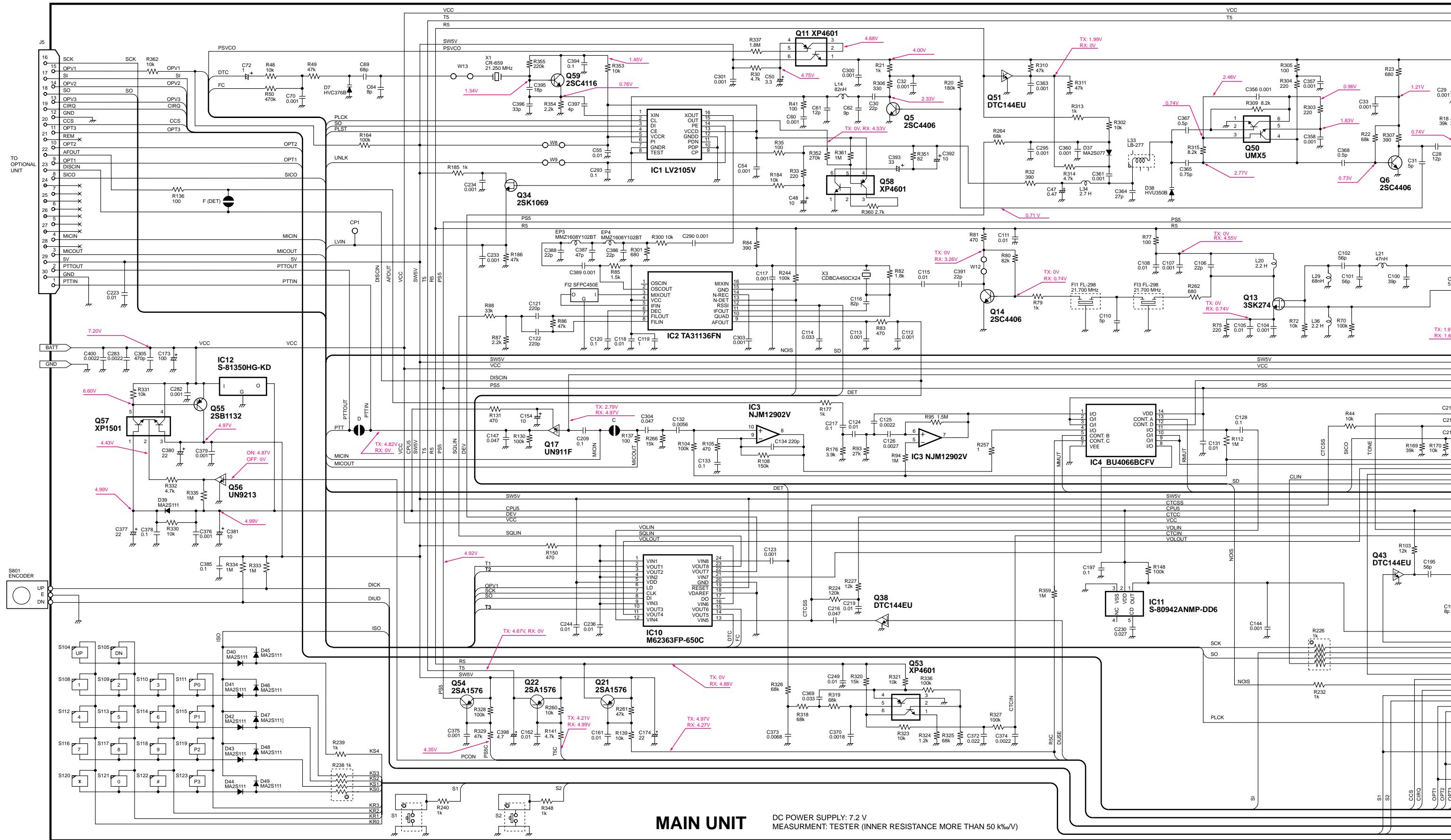

MAIN UNIT

DC POWER SUPPLY: 7.2 V
MEASUREMENT: TESTER (INNER RESISTANCE MORE THAN 50 kΩ/V)

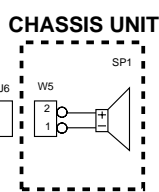
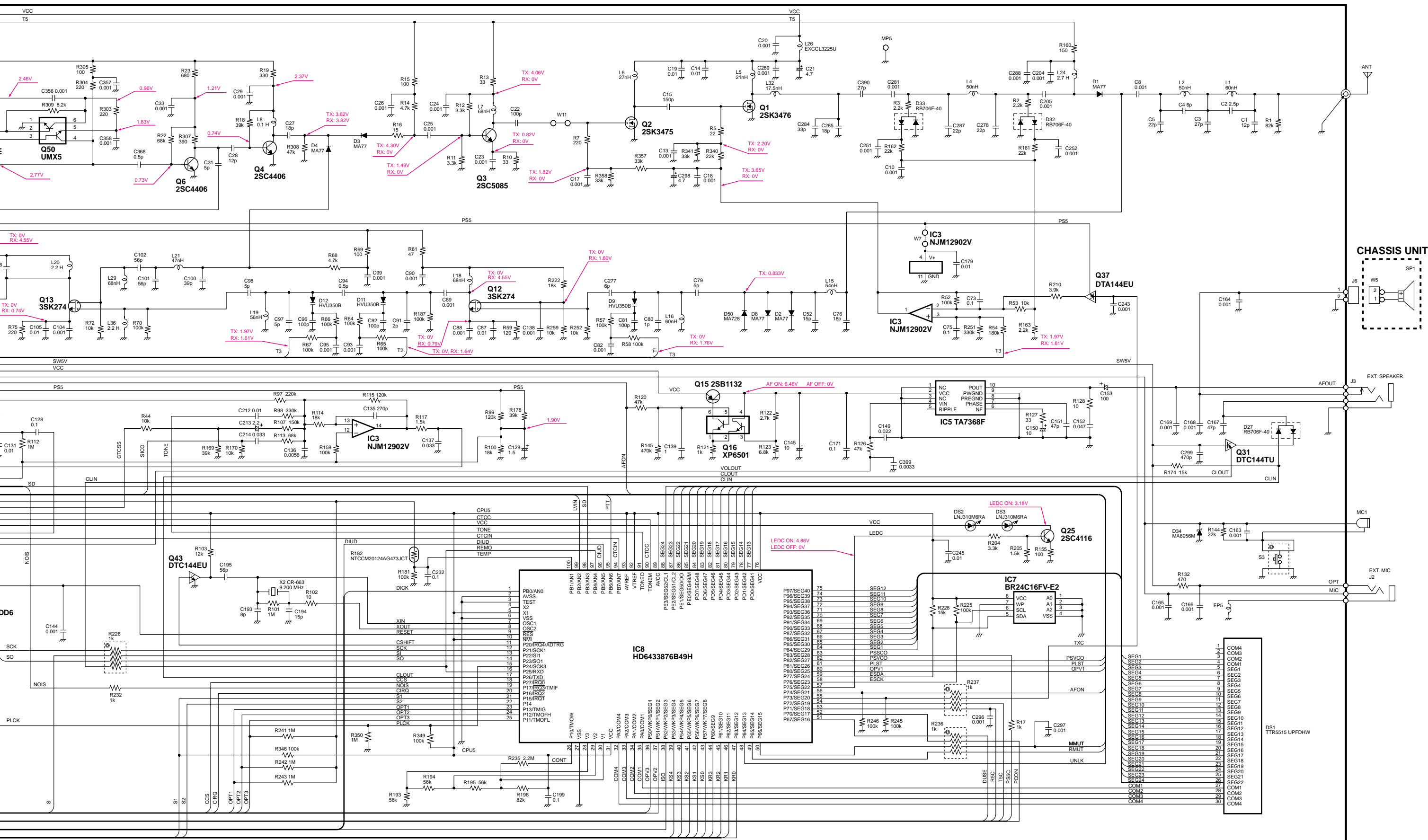

IC8
HD6433876B49H

IC7
BR24C16FV-E2

IC5
TA7368F

IC3
NJM12902V

Q15
2SB1132

Q16
XP6501

Q1
2SK3476

Q2
2SK3475

Q3
2SC5085

Q4
2SC4406

Q6
2SC4406

Q13
3SK274

Q12
3SK274

Q7
DTA144EU

Q25
2SC4116

Q43
DTC144EU

Q50
UMX5

D1
MA77

D2
MA77

D3
MA77

D4
MA77

D50
MA728

D7
RB706F-40

D8
MA77

D9
HVU350B

D10
HVU350B

D11
HVU350B

D12
HVU350B

D13
HVU350B

D14
HVU350B

D15
HVU350B

D16
HVU350B

D17
HVU350B

D18
HVU350B

D19
HVU350B

D20
HVU350B

D21
HVU350B

D22
HVU350B

D23
HVU350B

D24
HVU350B

D25
HVU350B

D26
HVU350B

D27
RB706F-40

D28
RB706F-40

D29
RB706F-40

D30
RB706F-40

D31
RB706F-40

D32
RB706F-40

D33
RB706F-40

D34
MA8056M

D35
MA8056M

D36
MA8056M

D37
MA8056M

D38
MA8056M

D39
MA8056M

D40
MA8056M

D41
MA8056M

D42
MA8056M

D43
MA8056M

D44
MA8056M

D45
MA8056M

D46
MA8056M

D47
MA8056M

D48
MA8056M

D49
MA8056M

D50
MA8056M

SECTION 12 VOLTAGE DIAGRAM

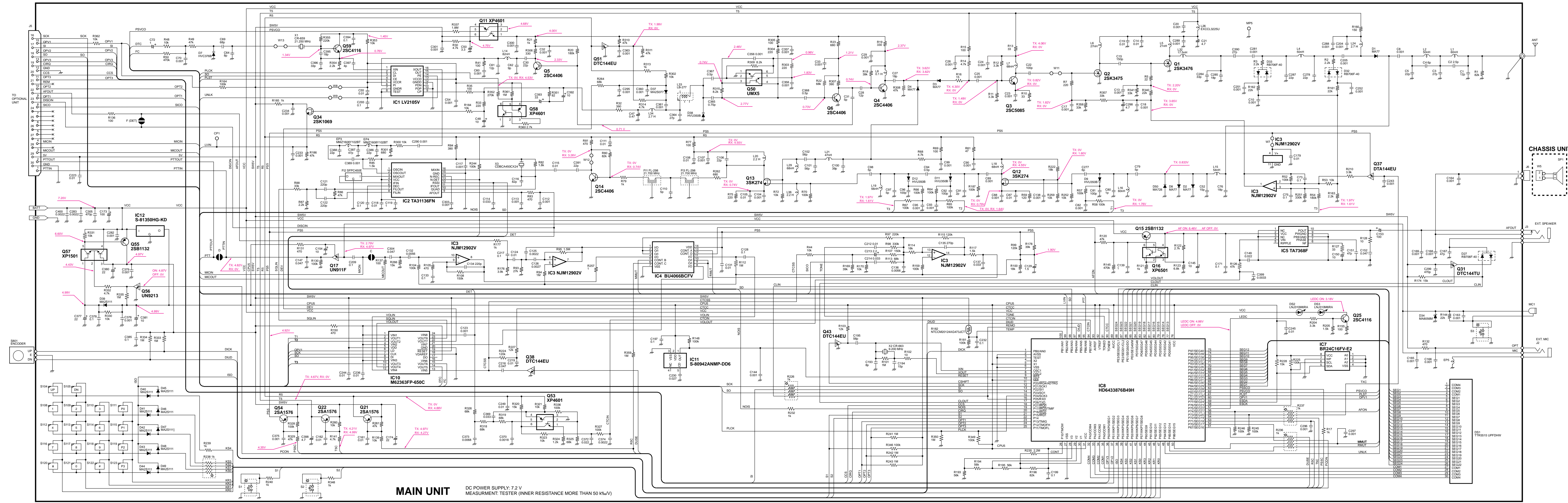

Icom Inc.

1-1-32, Kamiminami, Hirano-ku, Osaka 547-0003, Japan
Phone : 06 6793 5302
Fax : 06 6793 0013
URL : <http://www.icom.co.jp/world/index.html>

Icom America Inc.

<Corporate Headquarters>
2380 116th Avenue N.E., Bellevue, WA 98004, U.S.A.
Phone : (425) 454-8155 Fax : (425) 454-1509
URL : <http://www.icomamerica.com>
<Customer Service>
Phone : (425) 454-7619

Icom Canada

Glenwood Centre #150-6165
Highway 17 Delta, B.C., V4K 5B8, Canada
Phone : (604) 952-4266 Fax : (604) 952-0090
URL : <http://www.icomcanada.com>

Icom (Australia) Pty. Ltd.

A.B.N. 88 006 092 575
290-294 Albert Street, Brunswick, Victoria, 3056, Australia
Phone : 03 9387 0666 Fax : 03 9387 0022
URL : <http://www.icom.net.au>

Icom New Zealand

146A Harris Road, East Tamaki,
Auckland, New Zealand
Phone : 09 274 4062 Fax : 09 274 4708
URL : <http://www.icom.co.nz>

Icom (Europe) GmbH

Communication Equipment
Himmelgeister Str. 100, D-40225 Düsseldorf, Germany
Phone : 0211 346047 Fax : 0211 333639
URL : <http://www.icomeurope.com>

Icom Spain S.L

Crta. de Gracia a Manresa Km. 14,750
08190 Sant Cugat del Valles Barcelona, SPAIN
Phone : (93) 590 26 70 Fax : (93) 589 04 46
URL : <http://www.icomspain.com>

Icom (UK) Ltd.

Unit 9, Sea St., Herne Bay, Kent, CT6 8LD, U.K.
Phone : 01227 741741 Fax : 01227 741742
URL : <http://www.icomuk.co.uk>

Icom France S.a

Zac de la Plaine, Rue Brindejanc des Moulinais
BP 5804, 31505 Toulouse Cedex, France
Phone : 561 36 03 03 Fax : 561 36 03 00
URL : <http://www.icom-france.com>

Asia Icom Inc.

6F No. 68, Sec. 1 Cheng-Teh Road, Taipei, Taiwan, R.O.C.
Phone : (02) 2559 1899 Fax : (02) 2559 1874

Count on us!